



Pyrotek[®]

BUILDING SUMMARY



pyroteknc.com

INDEX | building

COMPANY PROFILE POLICIES

1 ACOUSTIC LAGGING

Wastewater pipes, HVAC, hydraulic pipes, compressors, pump wraps and fan housings.

2 SOUND ABSORBERS

Vent shafts, elevator shafts, plant rooms, outdoor rooftop enclosures, interior wall and ceiling linings.

3 NOISE BARRIERS | COMPOSITES

Inside cavities, ceilings, between the plenum chamber of a floor slab, the roof and adjoining partition walls, outdoor enclosure.

4 VIBRATION CONTROL | ISOLATION CONTROL

Metal roofing, floors, wall cladding, HVAC, plant rooms, and garbage chutes.

5 ANTI-CONDENSATION | TEMPERATURE REDUCTION

Applications exposed to high humidity and surface temperature fluctuations (pipes, walls, building interiors etc.), underside of metal deck roofing and metal wall cladding.

6 CASE STUDIES | PROJECT LIST

Pyrotek® product case studies and a list of products that have been applied to building projects around the world.

With ISO 9001 quality system certification, our global engineering team design highly specialised products to every specification and performance requirement. Our products are independently certified, time tested and supported by proven results.

COMPANY PROFILE

Pyrotek® is a global engineering leader and innovator of performance-improving technical solutions, integrated systems design and consulting services for customers in the aluminium industry. We are also investing and growing rapidly in areas such as glass, noise control and advanced materials.

We have global resources and dependable local support in more than 35 countries with over 80 locations. Our products and solutions are in use around the world in automotive, aerospace, rail transportation and high-tech manufacturing.

Privately-owned since 1956, our deep-rooted values of integrity and collaborative problem-solving uphold our mission to improve customer performance.

WHO WE ARE

- A global engineering innovator and supplier of complete end-to-end, performance improving technical solutions
- Our Noise Control division began in Australia, bringing over 30 years experience
- We supply complete turn-key solutions for many industries with over 300 Pyrotek application engineers, worldwide

WHY CHOOSE US

- Strong R&D Laboratory Team - ceramic, acoustic & chemical engineers help maximise product performance
- Extensive data analysis and noise predictions
- Design capabilities using CAD and 3D modelling
- Global test laboratories for fire, acoustic and vibration

OUR INDUSTRIES



Building



Industrial



Transportation



Marine



Oil & Gas



SUSTAINABILITY POLICY

Pyrotek is committed to ethical corporate citizenship and to promote sustainability in its activities and environmental responsibility. We will treat the environment as a valued legacy for our grandchildren. While Pyrotek recognizes that its business activities have environmental and social implications, Pyrotek is committed to mitigate any environmental or social impact its business activities may have through the adoption of best practices and policies. Pyrotek will contribute to the development of a sustainable future through the following principles.

PRINCIPLES

1. Practice responsible corporate conduct through adoption of workplace policies and best practices that meet or exceed regulatory and statutory requirements and that develop and maintain an entrepreneurial and collegial environment.
2. Manage risks, including those related to environmental, social and governance aspects.
3. Identify opportunities to contribute to the development of society and future generations.
4. Provide a safe, healthy and enriching working environment for Pyrotek employees.
5. Be a fair and responsible member of the communities in which Pyrotek operates.
6. As employees and as a company, be ethical and responsible citizens.
7. Be a responsible steward of resources.
8. Adhere to Pyrotek's Environmental Policy to limit its carbon footprint.
9. Pyrotek encourages the adoption of similar principles by its supply chain and business partners.



ENVIRONMENTAL PRODUCT STATEMENT

OUR COMMITMENT TO SAFETY, QUALITY AND ENVIRONMENT

Pyrotek is committed to safely produce quality products and services, on-time and at a competitive cost. This enables Pyrotek to build a sustainable business for the benefit of our customers, employees and stakeholders. Our focus is dedicated to developing systems with new, more considered operations and materials, as well as committing to improved technologies to further support long-term goals of safety, quality and environment.

Environmental Consideration

We acknowledge the need for consideration for our manufacturing activities to contribute to the mitigation of global warming via energy savings. We locally commit to reducing environmental impact by the prevention of pollution, minimization of waste and reduction of energy and water we use.

Ozone Depleting Potential

Pyrotek has undertaken an audit of its raw materials supplied and manufactured products barrier referencing to the US EPA List of Ozone Depleting Substances (Class 1 and Class 2). To the best of our knowledge, no ozone depleting substances are involved in either the manufacture or composition of these products.

Volatile Organic Compounds (VOC)

Products supplied by Pyrotek do not contain any significant Volatile Organic Compounds (VOCs) content when evaluated to the differing definitions as applied under the Australia National Pollutant Inventory, The Council of the European Union, Council Directive 1999/13/EC or the USA EPA Regulation 40 CFR 51.100(s). We also test to ASTM D5116 showing low VOC release.

Asbestos free manufacturing

Asbestos is not used during the manufacture of, and not added during any process of during the processing of our products. Please contact Pyrotek for available test reports to AS4964.

Global Warming Potential

Pyrotek's acoustic product range is designed with a reduced carbon footprint in mind, using locally sourced and environmentally-certified materials where possible. We use no CFCs, HCFCs or known high-GWP gases in our manufacturing process.

Recycle and emission care

During the process of manufacture, every care is taken to recycle and reuse material and where possible our plant and equipment has emission cleaners fitted.

CODE OF BUSINESS ETHICS

POLICY

This Code of Business Conduct and Ethics (the “Code”) represents the commitment of Pyrotek Inc. (which, together with all subsidiaries, is referred to as the “Company”) to conduct its business with integrity, in accordance with all applicable laws, rules and regulations and with high ethical standards. All employees, officers and general managers of the Company are expected to adhere to the principals and procedures set forth in the Code. However, no code can govern all possible situations. Therefore, those individuals governed by the Code must apply the spirit, as well as the letter, of this Code and request guidance from those identified below in the event of any question of interpretation. In all instances, each individual should strive to uphold the integrity and credibility of the Company. This Code is also supplemented by the rules of business conduct and ethics contained in the Company’s other policies and procedures.

Note: This Code is subject to review and modification. The form of the Code made available on the Policies and Procedures Database of the Company supersedes any prior expression of the policy to the extent of any inconsistency. The following sections highlight key scenarios where the Code will govern individual behavior.

PROCEDURE

CONFLICT OF INTEREST

A “conflict of interest” occurs when an individual’s private interests interfere, or appears to interfere, in any way with the interests of the Company. A conflict of interest can arise when an employee, officer or director takes actions or has a personal or non-Company related business interest that may make it difficult to perform his or her Company work objectively and effectively. Conflicts of interest also arise when an employee, officer or director, or a member of his or her family, receives improper personal benefits as a result of his or her position in the Company. Loans to or guarantees of obligations of such persons are of special concern as conflicts of interest. Service to the Company should never be subordinated to personal gain and advantage.

All conflicts of interest as described above are prohibited. Each employee, officer and director should be careful to avoid a conflict of interest by avoiding actions or relationships that may either make it difficult to perform Company work objectively and effectively or affect personal judgment regarding what is in the Company’s best interest.

Any individual who has any questions or concerns regarding this policy, or any specific situations, actions or omissions which may relate to or be prohibited by this policy, is encouraged to discuss such questions or concerns with any of the following individuals: the Company’s (1) President, (2) Chief Financial Officer or (3) Corporate Counsel.

CORPORATE OBLIGATION

Employees, officers and general managers owe a duty to the Company to advance its legitimate interests when the opportunity to do so arises. Each employee, officer and director is prohibited from:

1. Taking for themselves personal opportunities that are discovered through the use of Company property, information or position;
2. Using Company property, information or position for personal gain; or
3. Competing with the Company.



CONFIDENTIALITY

Employees, officers and general managers should maintain the confidentiality of confidential and proprietary information entrusted to them by the Company and its guests and customers, except when disclosure is authorized or legally mandated. Confidential information includes all nonpublic information that might be of use to competitors of the Company, or harmful to the Company or its guests or customers if disclosed.

Employees, officers and general managers are encouraged to consult the CFO, prior to making any disclosure, with any questions regarding whether a legal obligation to disclose confidential information exists. The obligation to maintain confidentiality extends indefinitely after a person's association with the Company as an employee, officer and director has ended.

FAIR DEALINGS

Each employee, officer and director should endeavor to deal fairly with the Company's customers, suppliers, competitors and employees. No employee, officer or director should take unfair advantage of anyone through manipulation, concealment, abuse of privileged information, misrepresentation of material facts or any other unfair dealing practice. Nothing contained in this paragraph shall in any way alter any existing legal rights and obligations of the Company or its employees, officers or general managers.

PROTECTION AND PROPER USE OF COMPANY ASSETS

Company employees, officers and general managers should protect the Company's assets and ensure their efficient use. Each employee, officer and director should endeavor to prevent misuse, loss, damage, sabotage or theft of Company assets. All Company assets should be used for legitimate business purposes only.

COMPLIANCE WITH LAWS, RULES AND REGULATIONS; REPORTING ILLEGAL OR UNETHICAL BEHAVIOR

The Company is committed to complying with all laws, rules and regulations applicable to it, including, but not limited to, those impacting the obligation of the Company to present all financial information to the public in conformance with generally accepted accounting principles based upon information which accurately reflects all relevant facts.

COMPLIANCE AND REPORTING

Employees, officers and general managers should strive to identify and raise potential issues before they lead to problems, and should ask about application of this Code whenever in doubt. Any employee, officer or general manager who becomes aware of any existing or potential violation of this Code should promptly notify the individual responsible for enforcement identified in the Section entitled "Policies and Procedures for Interpretation and Enforcement of the Code".

POLICIES AND PROCEDURES FOR INTERPRETATION AND ENFORCEMENT OF THE CODE

The President, General Counsel and Chief Financial Officer are responsible for applying this Code to specific situations relating to violations of the Code by general managers and executive officers and to specific situations relating to violations of the Code by other employees which have a material adverse effect on the Company's overall operations or financial position.

Company management will handle violations of the Code by individuals other than general managers or executive officers in the same manner that other violations of Company policies are handled and it is expected that most violations occurring in the ordinary course of the Company's business will not be sufficiently material to require report to the Shareholders of the Company or the President.

WAIVERS

From time to time, the Company may waive certain provisions of this Code. Any employee, officer or general manager who believes that a waiver may be appropriate should discuss the matter with the President.

ACOUSTIC LAGGING | foam

The highly flexible **foam-based** acoustic pipe lagging product range developed to reduce breakout noise from wastewater pipes, valves, fan housings and ductwork in commercial, industrial and residential buildings.

SOUNDLAG®

The premium blue convoluted foam Soundlag® grade.

International fire standards including BS, AS/NZS, and ISO. It is also equipped with a fire-resistant aluminium foil facing that achieved a Class 0 rating.

Tested to AS/NZS 1530.3 with excellent flame resistance.

Low VOC emission exceeds Green Star rating of <0.5 mg/m²/h.

Convoluted grades available

Soundlag® 4525C

Soundlag® 8025C

Soundlag® LW

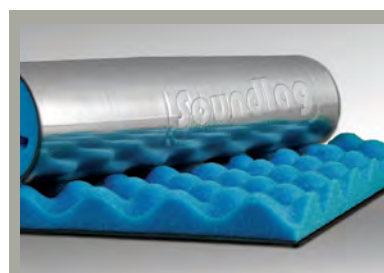

Soundlag® 4525C

reduces noise by up to

25 dB(A)

in hydraulic and wastewater pipes.

All Soundlag grades

Standard roll size

Soundlag 4525C

1.35 m x 5 m (4.4 ft x 16.4 ft)

Soundlag 8025C and Soundlag LW

1.35 m x 3 m (4.4 ft x 9.8 ft)

Soundlag LW

0.675 m x 5 m (2.2 ft x 16.4 ft)

Various roll sizes available (4525C):

0.675 m x 5 m (2.2 ft x 16.4 ft), and

1.35 m x 3 m (4.4 ft x 9.8 ft)

SOUNDLAG® 4512

The grey plain foam Soundlag® grade.

Includes fire-resistant aluminium foil facing that has been tested to international fire standard achieving a Class 0 rating.

Available in 6 mm foam thickness.



Soundlag® 4512

reduces noise by up to

23 dB(A)

in hydraulic and wastewater pipes.

Application:

All Soundlag® foam grades can be used on wastewater pipes, hydraulic pipes, compressors, pump wraps, HVAC and fan housings.

ACOUSTIC LAGGING | glass wool

Soundlag GW & QGW consist of an aluminium foil-faced mass-loaded vinyl laminated to a decoupling layer. The decoupling layer is a 25 mm thick, lightweight, non-combustible **glass wool** for improved fire-resistance.

SOUNDLAG® GW & QGW

Soundlag® glass wool and quilted glass wool grade.

Aluminium foil facing tested to international fire standard achieving a Class 0 rating

Soundlag® 4525GW achieves R_w / STC 28 rating for barrier layer

Broad operating temperature range.

Soundlag® QGW provides a quilted option to prevent the shedding of fibres.

Grades available:

Soundlag® 4525GW
Soundlag® 4525QGW
Soundlag® 4550GW
Soundlag® 8025GW



GW grades

Standard roll size
1.35 m x 5 m
(4.4 ft x 16.4 ft)

Custom sizes available
depending on MOQ

QGW grades

Standard roll size
1.22 m x 5 m
(4 ft x 16.4 ft)

Custom sizes available
depending on MOQ

Application:

All Soundlag® glass wool grades can be used on wastewater pipes, hydraulic pipes, compressors, pump wraps, HVAC and fan housings.

Technical Datasheet



SOUNDLAG®

foam-based pipe and duct lagging

Soundlag is a highly flexible foam-based composite acoustic pipe lagging product. It was developed to reduce breakout noise from wastewater pipes, valves, fan housings and ductwork in commercial, industrial and residential buildings.

The product range complies to international fire standards to meet fire safety demands in buildings. All Soundlag products are also equipped with a aluminium foil facing that achieves a Class 0 rating.

Soundlag 4525C provides an optimal soundproofing solution for those seeking compliance to BCA (Building Code of Australia) F5.6 requirements for habitable and non-habitable rooms. Based on test results, Soundlag™ 4525C can offer a significantly higher performance of up to 5 dB(A) compared to low noise pipe products especially in areas with no ceiling or with penetrations.

The highly dense flexible mass layer delivers excellent sound reduction properties. Soundlag's decoupling layer breaks the vibration path between the substrate and the mass barrier, allowing the vinyl wrap to remain flexible - optimising performance.

Pyrotek Soundlag is available in a variety of compositions to meet customer requirement. Barrier weights are available in 3 kg/m² to 8 kg/m² with convoluted foam, plain foam, polyester or glass wool backing in thicknesses ranging from 6 mm to 50 mm.

Alternative colour options to the reinforced aluminium facing are black and white foil. These anti-glare foil colours are suitable for exposed ceiling spaces.

VOC, ODP, HEALTH AND SAFETY

Soundlag is non-toxic and safe to handle by methods prescribed in the Safety Data Sheet. No ozone depleting substances are used during the manufacture of Soundlag.

SPECIFICATIONS

Colour	Silver (Aluminium foil facing) Blue convoluted (Soundlag 4525C) Plain grey foam (Soundlag 4512) <i>(Available with black and white foil)</i>
Available	Standard roll size: 1.35 m x 5 m (4.4 ft x 16.4 ft) <i>Various roll sizes available including:</i> 0.675 m x 5 m (2.2 ft x 16.4 ft) 1.35 m x 3 m (4.4 ft x 9.8 ft) Custom sizes available depending on MOQ



applications

- Wastewater pipes
- Hydraulic pipes
- Compressor and pump wraps
- HVAC
- Fan housings

features

- Better performance - up to 5 dB(A) with Soundlag 4525C compared to low noise pipe products without ceiling or areas with penetrations
- Class 0 aluminium foil facing
- Tested to AS/NZS 1530.3 with excellent flame resistance (4525C)
- Soundlag range complies to international fire standards
- Broad operating temperature range
- Reduces the noise in hydraulic and wastewater pipes by up to 25.2 dB(A)
- Free from odour producing oils and bitumen
- Contain no ozone depleting substances
- Choice of blue convoluted foam, grey plain foam, polyester or glass wool
- Simple to install - can be cut to size
- Easy to bond - matching Tape ALR or equivalent
- Endorsed and tested by leading acoustic consultants and engineers



PRODUCT SPECIFICATIONS

Product	Standard thickness	Standard roll weight	Standard roll size	Barrier weight	Operating Temperature range
Soundlag® 4525C	25 mm (0.98 in)	37 kg (82 lb)	1.35 x 5 m (4.4 ft x 16.4 ft)	5 kg/m ² (1 lb/ft ²)	Continuous: -40 to 100 °C (-40 to 212 °F) Intermittent: -40 to 120 °C (-40 to 248 °F)
Soundlag® 4512	14 mm (0.55 in)	36 kg (79 lb)		4.5 kg/m ² (0.92 lb/ft ²)	

Tolerances: Length: ±1%, Width: -0/+5 mm (0.2 in), Thickness: ±5 mm (0.2 in), Weight: ±10%

MATERIAL PROPERTIES

Product	Test method	Property	Report	Results
Soundlag® 4525C	AS/NZS 1530.3	Ignitability, flame propagation, heat and smoke release	16-004295	0,0,0,1
	AS/NZS 3837, ISO 5660-1 & ISO 5660-2	Fire hazard properties	FH 5997-T0	Group 3
	ASTM C518	Thermal conductivity	DI0324/DU01	0.0476 W/mK
	BS 476 Part 6	Fire propagation	381636	Class 0 foil facing
	BS 476 Part 7	Surface spread of flame	381638	
	ASTM D5116	TVOC specific area emission rate	CV 100812	Emissions are less than the Green Star recognised threshold of 0.5 mg/m ² /hr
	AS 4964	Asbestos Testing	318653	No Asbestos Detected
Soundlag® 4512	AS/NZS 3837, ISO 5660-1 & ISO 5660-2	Fire hazard properties	FH 5242-TT	Group 3
	UL 94	Flammability of plastic materials	7-547751-CV	HBF
	BS 476 Part 6	Fire propagation	381636	Class 0 foil facing
	BS 476 Part 7	Surface spread of flame	381638	
	ASTM D5116	TVOC specific area emission rate	CV 100812	Emissions are less than the Green Star recognised threshold of 0.5 mg/m ² /hr

ACOUSTIC PERFORMANCE

Product	Test	Report	Result
Soundlag® 4525C	Insertion loss (single layer)	ATF750B	25 dB
	Insertion loss (double layer)	nss22253b	29 dB
	NCC BCA Volume 1 F5.6 - Sound insulation rating of internal services: Habitable room	Lt 002 20161709	Suitable with ≥10 mm plasterboard*
	NCC BCA Volume 1 F5.6 - Sound insulation rating of internal services: Non-habitable room	Lt 01 r02 2010167	Suitable without ceiling*
	AAAC Rating (Association of Australasian Acoustical Consultants - Apartment and Townhouse Acoustic Rating)	PKA-A186	6 Star Rating
	Transmission loss (ISO 15186-1 & ISO 10140-4)	189 (rev 1)c	Rw 28, STC 28 (barrier layer only)
Soundlag® 4512	Insertion loss (single layer)	ATF750C	23 dB
	Transmission loss (ISO 15186-1 & ISO 10140-4)	189 (rev 1)c	Rw 28, STC 28 (barrier layer only)

*Please see report for further information

Frequency (Hz)	4525C (dB)	4512 (dB)
100	5.6	2.5
125	8.5	3.8
160	2.7	4.2
200	2.0	0.2
250	5.2	2.9
315	5.8	6.2
400	8.2	6.5
500	10.8	8.3
630	15.4	10.8
800	17.2	14.3
1000	20.2	17.4
1250	22.4	19.9
1600	24.1	21.6
2000	27.4	24.3
2500	30.9	26.6
3150	34.1	29.1
4000	36.3	32.0
5000	35.7	32.6
Insertion Loss	25	23

Tested at National Acoustic Laboratories, Australia
Report Numbers: ATF750B, ATF750C

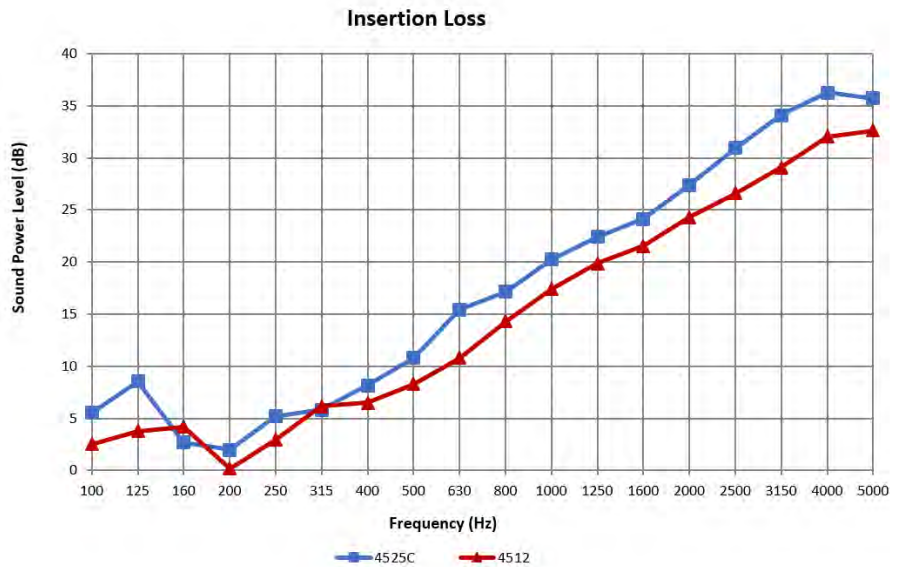

For further information and contact details, please visit our website pyroteknc.com

Caveats: Specifications are subject to change without notice. The data in this document is typical of average values based on tests by independent laboratories or by the manufacturer and are indicative only. Materials must be tested under intended service conditions to determine their suitability for purpose. The conclusions drawn from acoustic test results are as interpreted by qualified independent testing authorities. Nothing here releases the purchaser/user from responsibility to determine the suitability of the product for their project needs. Always seek the opinion of your acoustic, mechanical or fire engineer on data presented by the manufacturer. Due to the wide variety of individual projects, Pyrotek is not responsible for differing outcomes from using their products. Pyrotek disclaims any liability for damages or consequential loss as a result of reliance solely on the information presented. No warranty is made that the use of this information or of the products, processes or equipment to which this Information Page refers will not infringe any third party's patents or rights. **DISCLAIMER:** This document is covered by Pyrotek standard Disclaimer, Warranty and © Copyright clauses. See pyroteknc.com/disclaimer.



SOUNDLAG® LW

foam-based pipe and duct lagging

Soundlag is a highly flexible foam-based composite acoustic pipe lagging product. It was developed to reduce breakout noise from wastewater pipes, valves, fan housings and ductwork in commercial, industrial and residential buildings.

The product range complies to international fire standards to meet fire safety demands in buildings. All Soundlag products are also equipped with a aluminium foil facing that achieves a Class 0 rating.

Soundlag LW provides an optimal soundproofing solution for those seeking compliance to BCA (Building Code of Australia) F5.6 requirements for habitable rooms.

The highly dense flexible mass layer delivers excellent sound reduction properties. Soundlag's decoupling layer breaks the vibration path between the substrate and the mass barrier, allowing the vinyl wrap to remain flexible - optimising performance.

Pyrotek Soundlag is available in a variety of compositions to meet customer requirement. Barrier weights are available in 3 kg/m² to 8 kg/m² with convoluted foam, plain foam, polyester or glass wool backing in thicknesses ranging from 6 mm to 50 mm.

Alternative colour options to the reinforced aluminium facing are black and white foil. These anti-glare foil colours are suitable for exposed ceiling spaces.



VOC, ODP, HEALTH AND SAFETY

Soundlag is non-toxic and safe to handle by methods prescribed in the Safety Data Sheet. No ozone depleting substances are used during the manufacture of Soundlag.

SPECIFICATIONS

Colour	Silver (Aluminium foil facing) Blue convoluted <i>(Available with black and white foil)</i>
Available	Standard roll size: 0.675 m x 5 m (2.2 ft x 16.4 ft) 1.35 m x 3 m (4.4 ft x 9.8 ft)
	Custom sizes available depending on MOQ

applications

- Wastewater pipes
- Hydraulic pipes
- Compressor and pump wraps
- HVAC
- Fan housings

features

- Class 0 aluminium foil facing
- Tested to AS/NZS 1530.3 with excellent flame resistance
- Soundlag range complies to international fire standards
- Broad operating temperature range
- Free from odour producing oils and bitumen
- Contain no ozone depleting substances
- Choice of blue convoluted foam, grey plain foam, polyester or glass wool
- Simple to install - can be cut to size
- Easy to bond - matching Tape ALR or equivalent
- Endorsed and tested by leading acoustic consultants and engineers



PRODUCT SPECIFICATIONS

Product	Standard thickness	Standard roll size	Barrier weight	Operating Temperature range
Soundlag® LW	25 mm (0.98 in)	0.675 m x 5 m (2.2 ft x 16.4 ft) 1.35 m x 3 m (4.4 ft x 9.8 ft)	3.0 kg/m ² (0.61 lb/ft ²)	Continuous: -40 to 100 °C (-40 to 212 °F) Intermittent: -40 to 120 °C (-40 to 248 °F)

Tolerances: Length: ±1%, Width: -0/+5 mm (0.2 in), Thickness: ±5 mm (0.2 in), Weight: ±10%

MATERIAL PROPERTIES

Product	Test method	Property	Report	Results
Soundlag® LW	AS/NZS 1530.3	Ignitability, flame propagation, heat and smoke release	24-000495	0,0,0,6
	BS 476 Part 6	Fire propagation	381636	Class 0 foil facing
	BS 476 Part 7	Surface spread of flame	381638	
	ASTM D5116	TVOC specific area emission rate	CV 100812	Emissions are less than the Green Star recognised threshold of 0.5 mg/m ² /hr

ACOUSTIC PERFORMANCE

Product	Test	Report	Result
Soundlag® LW	NCC BCA Volume 1 F5.6 - Sound insulation rating of internal services: Habitable room	TN492-03F02	Suitable with ≥10 mm plasterboard*

*Please see report for further information

For further information and contact details, please visit our website pyroteknc.com

Caveats: Specifications are subject to change without notice. The data in this document is typical of average values based on tests by independent laboratories or by the manufacturer and are indicative only. Materials must be tested under intended service conditions to determine their suitability for purpose. The conclusions drawn from acoustic test results are as interpreted by qualified independent testing authorities. Nothing here releases the purchaser/user from responsibility to determine the suitability of the product for their project needs. Always seek the opinion of your acoustic, mechanical or fire engineer on data presented by the manufacturer. Due to the wide variety of individual projects, Pyrotek is not responsible for differing outcomes from using their products. Pyrotek disclaims any liability for damages or consequential loss as a result of reliance solely on the information presented. No warranty is made that the use of this information or of the products, processes or equipment to which this Information Page refers will not infringe any third party's patents or rights. DISCLAIMER: This document is covered by Pyrotek standard Disclaimer, Warranty and © Copyright clauses. See pyroteknc.com/disclaimer.



SOUNDLAG® 8025C

acoustic duct lagging

Soundlag® 8025C is a high-performance composite acoustic lagging product developed to reduce noise from valves, fan housings and ductwork in commercial, industrial and domestic buildings.

The highly dense and flexible mass layer provides excellent sound reduction properties, whilst the decoupling layer breaks the vibration path between substrate and the mass barrier, allowing the vinyl external wrap to remain flexible - optimising performance.

The external foil facing offers a fire-resistant covering and an excellent surface to join adjacent sheets.

Pyrotek® offers varying compositions with barrier weights from 3 kg/m² to 8 kg/m² and the decoupling layer with a choice of foam (plain or convoluted), polyester, fibreglass or glass wool with thicknesses from 6 mm to 50 mm.



VOC, ODP, HEALTH AND SAFETY

Soundlag is non-toxic and safe to handle by methods prescribed in the Safety Data Sheet. No ozone depleting substances are used during the manufacture of Soundlag.

SPECIFICATIONS

Colour	Aluminium facing Blue convoluted foam backing
Available	Standard roll size: 1.35 x 3 m
	Custom sizes and weights are available depending on MOQ

applications

- Duct lagging
- Compressor and pump wraps
- HVAC
- Fan housings

features

- Free from odour producing oils and bitumen, resulting in low VOC
- Contain no ozone depleting substances
- Accredited to ISO 9001 Quality Control Standard
- Broad operating temperature range
- Varying range of weights and thicknesses
- Choice of foam, polyester, fibreglass or glass wool
- Can cut to size and simple to install
- Easy to bond - matching Tape ALR or equivalent
- Endorsed and tested by leading acoustic consultants



PRODUCT SPECIFICATIONS

Product name	Standard thickness	Roll weight	Standard Roll Size	Barrier weight	Thermal conductivity (W/mk)	Operating temperature range (°C)
Soundlag 8025C	29 mm	34 kg	1.35 x 3 m	8 kg/m ²	0.0476*	- 40 to 100 (continuous) - 40 to 120 (intermittent)

Tolerances: Length: ±1%; Width: - 0/+5 mm (0.2 in); Thickness: ±3 mm (0.12 in); Weight: ±10%

* Tested to ASTM C 518 (report BRANZ D10324)

MATERIAL PROPERTIES

Test method	Property	Report	Results
AS/NZS 1530.3	Ignitability, flame propagation, heat and smoke release	20-004854	0, 0, 0, 5

Frequency (Hz)	8 kg/m ²
100	13.3
125	16.2
160	22.6
200	20.5
250	22.3
315	23.2
400	25
500	26
630	28.6
800	30.1
1000	32.7
1250	33.4
1600	34.1
2000	35.9
2500	37.6
3150	39.7
4000	42.1
5000	45
Rw	31
STC	31

Tested to ISO 15186-1:2003 & 10140-4:2010 at University of Canterbury, New Zealand Report Number 264a

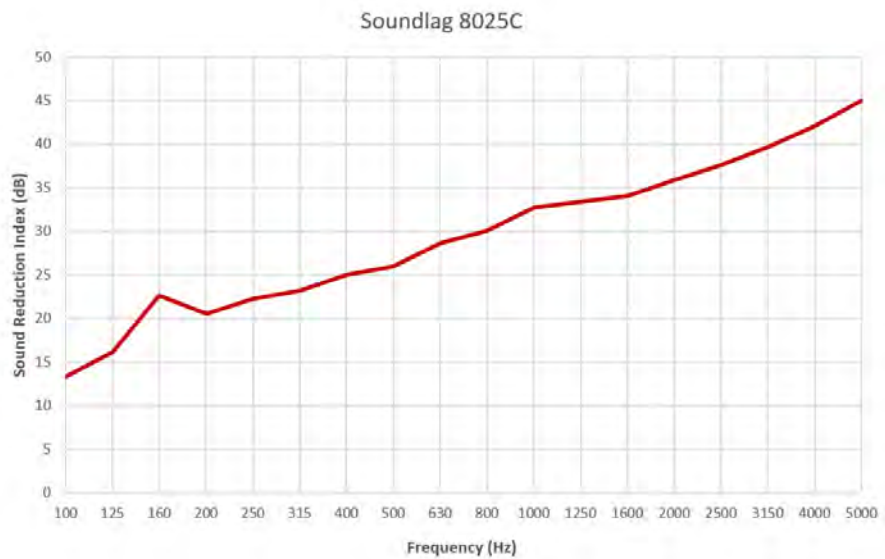

For further information and contact details, please visit our website pyroteknc.com

Caveats: Specifications are subject to change without notice. The data in this document is typical of average values based on tests by independent laboratories or by the manufacturer and are indicative only. Materials must be tested under intended service conditions to determine their suitability for purpose. The conclusions drawn from acoustic test results are as interpreted by qualified independent testing authorities. Nothing here releases the purchaser/user from responsibility to determine the suitability of the product for their project needs. Always seek the opinion of your acoustic, mechanical or fire engineer on data presented by the manufacturer. Due to the wide variety of individual projects, Pyrotek is not responsible for differing outcomes from using their products. Pyrotek disclaims any liability for damages or consequential loss as a result of reliance solely on the information presented. No warranty is made that the use of this information or of the products, processes or equipment to which this Information Page refers will not infringe any third party's patents or rights. DISCLAIMER: This document is covered by Pyrotek standard Disclaimer, Warranty and © Copyright clauses. See pyroteknc.com/disclaimer.



SOUNDLAG GW

glass wool pipe and duct lagging

Soundlag 4525GW is Pyrotek's standard grade, flexible acoustic lagging composite glass wool product. It was developed to reduce breakout noise from wastewater pipes, hydraulic pipes, and air-conditioning ducts.

Soundlag 4525GW consists of an aluminium foil-faced mass-loaded vinyl laminated to a decoupling layer. The decoupling layer is a 25 mm thick, non-combustible glass wool with a white scrim to prevent shedding of fibres. Soundlag 4525GW was designed to meet customer fire safety specifications.

The highly dense and flexible mass layer provides excellent sound reduction properties. Soundlag 4525GW's decoupling layer breaks the vibration path between the substrate and the mass barrier, allowing it to remain flexible – optimising acoustic performance.

All Soundlag products are easy to cut to size with a retractable utility knife, or scissors. They can be fitted following three easy steps - cut, wrap and tape.

VOC STATEMENT

Soundlag products contain no ozone-depleting substances and comply with European and Australian standards for Volatile Organic Compound emissions.

SPECIFICATIONS

Colour	Silver (Aluminium foil facing) Yellow (Glass wool)
Available	Standard roll size: 1.35 m x 5 m (4.4 ft x 16.4 ft)
	Custom sizes available depending on MOQ

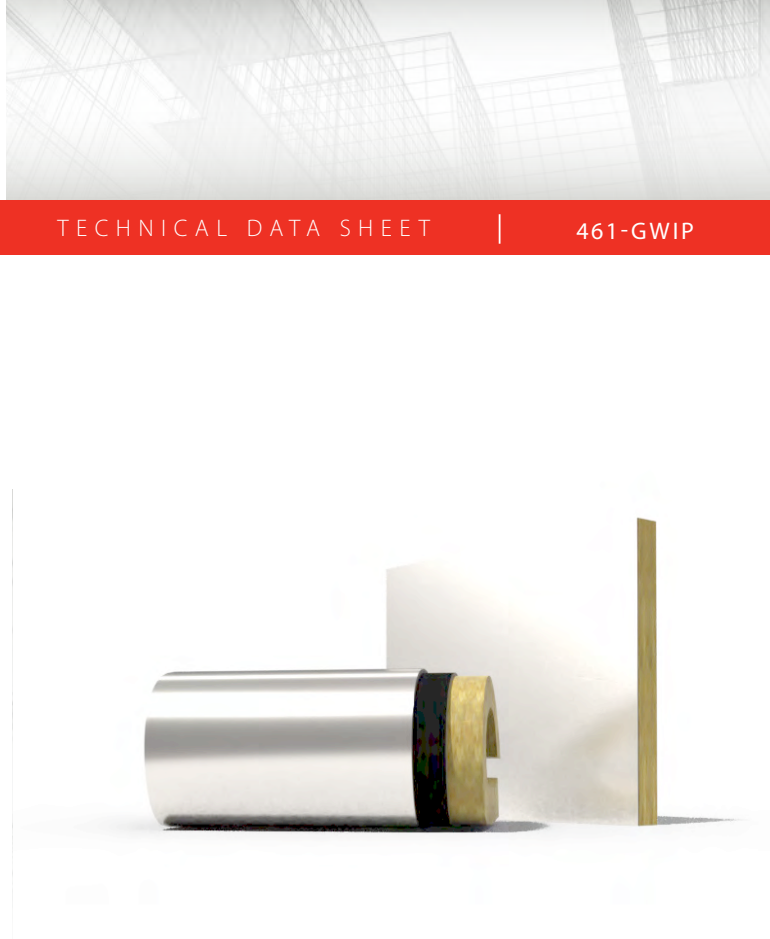

applications

- Wastewater pipes
- Hydraulic pipes
- Compressor and pump wraps
- Air conditioning ducts and shrouds
- Fan housings

features

- Tested to ASTM E84 - complies to international building codes to meet fire safety requirements
- Heat and light reflective facing
- Class 0 aluminium foil facing
- Low spread of flame surface
- This product is classed as low VOC emitting material
- Free from odour-producing oils and bitumen
- Reduces breakout noise from hydraulic and waste water pipes
- Broad operating temperature range
- Varying range of weights and thicknesses
- Easy to bond using matching Tape ALR adhesive or equivalent tape
- Can be cut to size with ease using a retractable utility knife or scissors

PRODUCT SPECIFICATIONS

Product name	Standard thickness	Roll weight	Barrier weight	Roll size	Operating temperature range
Soundlag 4525GW	27 mm (1.06 in)	39 kg (86 lb)	5 kg/m ² (1 lb/ft ²)	1.35 x 5 m (4.4 ft x 16.4 ft)	Continuous: -40 to 100 °C (-40 to 212 °F) Intermittent: -40 to 120 °C (-40 to 248 °F)

Tolerances: Length: ±1%, Width: -0/+5 mm (0.2 in), Thickness: ±3 mm (0.12 in), Weight: ±10%

PRODUCT CODE NOMENCLATURE

SOUNDLAG 4525 GW

Grade - 3025, 4525, 4550, 8050

Infill type - GW (glass wool)



MATERIAL PROPERTIES

Test method	Property	Report	Results
AS/NZS 1530.3	Ignitability, flame propagation, heat and smoke release	17-005837	0,0,0,2
BS 476 Part 6	Fire propagation	381636	Class 0 foil facing
BS 476 Part 7	Surface spread of flame	381638	
ASTM E84	Surface burning characteristics of building materials	103698958-SAT-001 REV2	Class A FSI = 0, SDI = 10
ASTM D5116	TVOC specific area emission rate	CV 100812	Emissions are less than the Green Star recognised threshold of 0.5 mg/m ² /hr
Qatar Civil Defence approval	Product approval	PAC19005619	Complies as fire rated and retardant materials
AS 4964	Asbestos Testing	318653	No Asbestos Detected
CAN/ULC S102.2	Test for surface burning characteristics	104572841COQ-001A R0	FSI: 0, SDI: 45

ACOUSTIC PERFORMANCE

Product	Insertion loss
Soundlag 4525GW	20.5 dB

Tested at National Acoustic Laboratories, Australia | Report Number: ATF749B

Product	Test method	Result
Soundlag 4525GW	ISO 10140	Rw 28, STC 28 (barrier layer only)

Tested at University of Canterbury, New Zealand | Report number: 189(rev 1)c

Insertion Loss

Frequency (Hz)	4525GW (dB)
100	5.9
125	6.4
160	3.1
200	0.0
250	0.4
315	5.3
400	5.0
500	6.6
630	9.7
800	11.3
1000	15.5
1250	18.5
1600	20.3
2000	22.2
2500	21.7
3150	26.5
4000	27.6
5000	26.9
Insertion Loss	20.5

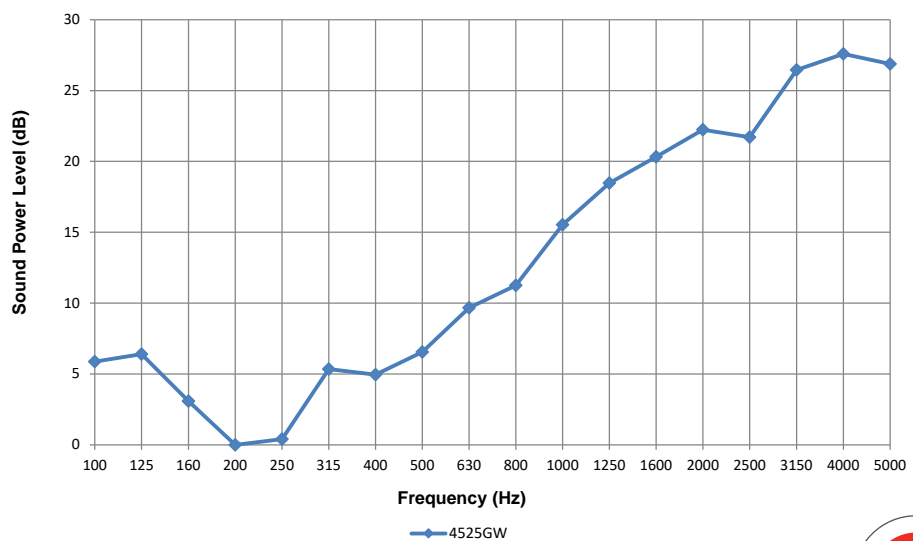

Tested at National Acoustic Laboratories, Australia | Report Number: ATF749B

For further information and contact details, please visit our website pyroteknc.com

Caveats: Specifications are subject to change without notice. The data in this document is typical of average values based on tests by independent laboratories or by the manufacturer and are indicative only. Materials must be tested under intended service conditions to determine their suitability for purpose. The conclusions drawn from acoustic test results are as interpreted by qualified independent testing authorities. Nothing here releases the purchaser/user from responsibility to determine the suitability of the product for their project needs. Always seek the opinion of your acoustic, mechanical and fire engineer on data presented by the manufacturer. Due to the wide variety of individual projects, Pyrotek is not responsible for differing outcomes from using their products. Pyrotek disclaims any liability for damages or consequential loss as a result of reliance solely on the information presented. No warranty is made that the use of this information or of the products, processes or equipment to which this Information Page refers will not infringe any third party's patents or rights.
DISCLAIMER: This document is covered by Pyrotek standard Disclaimer, Warranty and © Copyright clauses. See pyroteknc.com/disclaimer.



SOUNDLAG QGW

quilted glass wool pipe and duct lagging

Soundlag 4525QGW is Pyrotek’s standard grade, flexible acoustic lagging composite glass wool product. It was developed to reduce breakout noise from wastewater pipes, hydraulic pipes, and air-conditioning ducts.

Soundlag 4525QGW consists of an aluminium foil-faced mass-loaded vinyl laminated to a decoupling layer. The decoupling layer is a 25 mm thick, non-combustible glass wool with a quilted white scrim to prevent shedding of fibres. Soundlag 4525QGW was designed to meet customer fire safety specifications.

The highly dense and flexible mass layer provides excellent sound reduction properties. Soundlag 4525QGW decoupling layer breaks the vibration path between the substrate and the mass barrier, allowing it to remain flexible – optimising acoustic performance.

All Soundlag products are easy to cut to size with a retractable utility knife, or scissors. They can be fitted following three easy steps - cut, wrap and tape.

VOC STATEMENT

Soundlag products contain no ozone-depleting substances and comply with European and Australian standards for Volatile Organic Compound emissions.

SPECIFICATIONS

Colour	Silver (Aluminium foil facing) Yellow (Glass wool)
Available	Standard roll size: 1.22 x 5 m (4 ft x 16.4 ft) Custom sizes available depending on MOQ

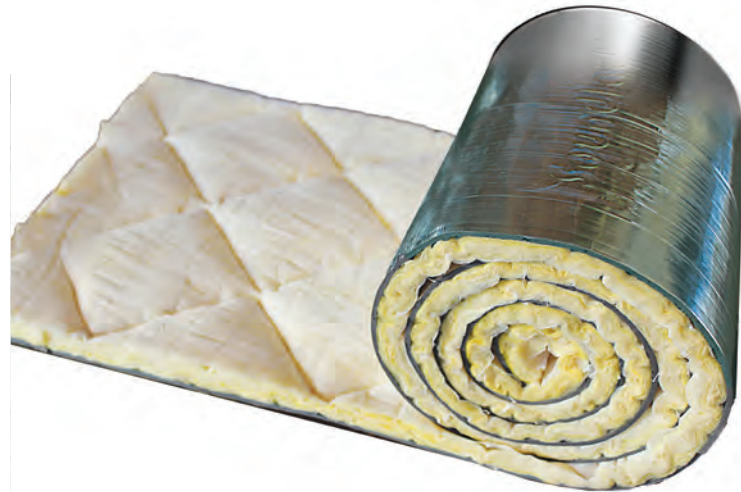

applications

- Wastewater pipes
- Hydraulic pipes
- Compressor and pump wraps
- Air conditioning ducts and shrouds
- Fan housings

features

- Tested to ASTM E84 - complies to international building codes to meet fire safety requirements
- Heat and light reflective facing
- Class 0 aluminium foil facing
- Low spread of flame surface
- This product is classed as low VOC emitting material
- Free from odour-producing oils and bitumen
- Reduces breakout noise from hydraulic and waste water pipes
- Broad operating temperature range
- Varying range of weights and thicknesses
- Easy to bond using matching Tape ALR adhesive or equivalent tape
- Can be cut to size with ease using a retractable utility knife or scissors



PRODUCT SPECIFICATIONS

Product name	Standard thickness	Glass wool density	Roll weight	Barrier weight	Roll size	Operating temperature range
Soundlag 4525QGW	27 mm (1.06 in)	32 kg/m ³ (2 lb/ft ³)	31 - 35 kg (68 - 77 lb)	5 kg/m ² (1 lb/ft ²)	1.22 x 5 m (4 ft x 16.4 ft)	Continuous: -40 to 100 °C (-40 to 212 °F) Intermittent: -40 to 120 °C (-40 to 248 °F)

Tolerances: Length: ±1%, Width: -0/+5 mm (0.2 in), Thickness: ±3 mm (0.12 in), Weight: ±10%

PRODUCT CODE NOMENCLATURE

SOUNDLAG 4525 QGW

Grade - 4525

Infill type - QGW (quilted glass wool)



MATERIAL PROPERTIES

Test method	Property	Report	Results
AS/NZS 1530.3	Ignitability, flame propagation, heat and smoke release	17-005837*	0,0,0,2
BS 476 Part 6	Fire propagation	381636	Class 0 foil facing
BS 476 Part 7	Surface spread of flame	381638	
ASTM E84	Surface burning characteristics of building materials	103698958-SAT-001 REV2*	Class A FSI = 0, SDI = 10
ASTM D5116	TVOC specific area emission rate	CV 100812*	Emissions are less than the Green Star recognised threshold of 0.5 mg/m ² /hr
AS 4964	Asbestos Testing	318653*	No Asbestos Detected
CAN/ULC S102.2	Test for surface burning characteristics	104572841COQ-001A R0*	FSI: 0, SDI: 45

* Test report for Soundlag 4525 GW (Glass wool not quilted)

ACOUSTIC PERFORMANCE

Test method	Property	Report	Results
Pyrotek method: Insertion loss	Sound reduction	ATF749B*	20.5 dB
ISO 10140	Transmission loss, Sound reduction index	189(rev 1)c **	Rw 28, STC 28

* Test report for Soundlag 4525 GW (Glass wool not quilted)

** Quadzero tested (barrier layer only)

Frequency (Hz)	4525GW (dB)
100	5.9
125	6.4
160	3.1
200	0.0
250	0.4
315	5.3
400	5.0
500	6.6
630	9.7
800	11.3
1000	15.5
1250	18.5
1600	20.3
2000	22.2
2500	21.7
3150	26.5
4000	27.6
5000	26.9
Insertion Loss	20.5

Insertion Loss

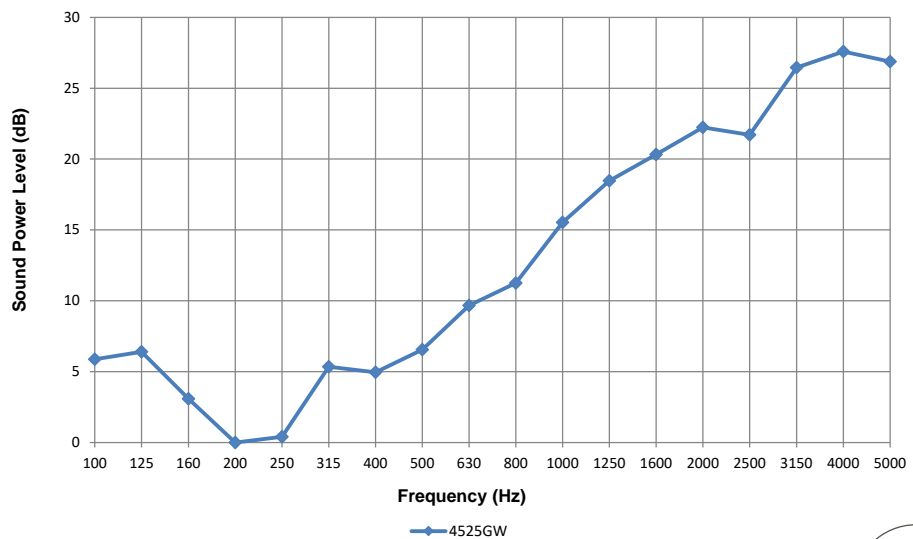

Tested at National Acoustic Laboratories, Australia | Report Number: ATF749B

For further information and contact details, please visit our website pyroteknc.com

Caveats: Specifications are subject to change without notice. The data in this document is typical of average values based on tests by independent laboratories or by the manufacturer and are indicative only. Materials must be tested under intended service conditions to determine their suitability for purpose. The conclusions drawn from acoustic test results are as interpreted by qualified independent testing authorities. Nothing here releases the purchaser/user from responsibility to determine the suitability of the product for their project needs. Always seek the opinion of your acoustic, mechanical and fire engineer on data presented by the manufacturer. Due to the wide variety of individual projects, Pyrotek is not responsible for differing outcomes from using their products. Pyrotek disclaims any liability for damages or consequential loss as a result of reliance solely on the information presented. No warranty is made that the use of this information or of the products, processes or equipment to which this Information Page refers will not infringe any third party's patents or rights. **DISCLAIMER:** This document is covered by Pyrotek standard Disclaimer, Warranty and © Copyright clauses. See pyroteknc.com/disclaimer.



Installation Guide



SOUNDLAG

The Installation Guide provides recommendations to maximise the service life in various applications. Soundlag pipe lagging gives the dual benefits of a noise barrier and a noise absorber.

WORKING HEALTH AND SAFETY

- Gloves, protective goggles and any other appropriate safety equipment based on local health & safety requirements and safe work practice must be worn by applicator.

DESCRIPTION

Soundlag is supplied in varying compositions with barrier weights of 3 to 8 kg/m² and the decoupling layer with a choice of foam, convoluted (4525C) or plain (4512), polyester or fibreglass with thicknesses from 6 mm to 50 mm.

Please refer to the Technical Data Sheet Soundlag 411IP

Soundlag is typically used to wrap noisy pipes, waste pipes, ducts, valves, and fan housings to prevent breakout noise from pipe walls or ducts.

The following is intended to serve as a general guide for installing Pyrotek pipe and duct lagging material around pipes and ducts.

PREPARATION

- Ensure pipe work pressure testing is complete and the pipe work surface is clean and dry before installing product.
- If the product has been stored on site for a period of time, ensure the material is clean, dry and free from oil and dirt or rips and tears.

ESSENTIALS FOR EFFECTIVE LAGGING

- Coverage of pipe by the lagging material must be continuous.
- There should be no gaps at joints or edges. The smallest of gaps at any joint will result in performance loss. (Refer section 'Treatment of Joints' further in this document)
- A tight seal around all joints and edges is critical for maximum performance. Use Pyrotek's pressure sensitive reinforced aluminium insulation tape - 'Tape ALR' or approved equal.
- Attention to detail and good workmanship in cutting, applying and fixing the product to the pipe is essential.

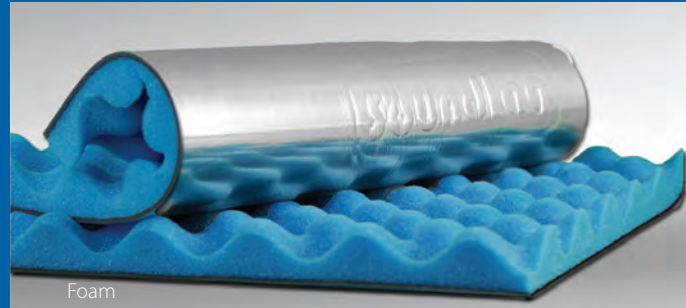

Soundlag is a high-performance composite acoustic pipe lagging product consisting of a reinforced aluminium foil faced, mass-loaded flexible vinyl noise barrier bonded to a decoupling layer.

applications

- Hydraulic and waste pipe lagging in all locations
- Air-conditioning duct lagging and shrouds
- Compressor wraps
- Spa motor wraps

HOW TO MEASURE AND CUT MATERIAL

For Straight Pipe Sections

Measure the length (L) and outside diameter (OD) of the pipe requiring lagging. Apply the following formula to calculate and cut the required wrapping width (W) of Soundlag. The formula allows for a 5 (five) per cent overlap.

$$W = \pi \times (OD + (2 \times T)) \times 1.05$$

OD = outside diameter of the pipe

$$\pi = 3.14 \text{ (pi)}$$

T = Total thickness of acoustic insulation (allow 20% compression on thickness when using convoluted foam or fibreglass decoupling layers.)

Mark the calculated width (W) along the length of the roll and cut material with a retractable knife or scissors (as shown in figures MR1 and CR1).

Soundlag is easy to cut to size with a retractable knife or scissors, minimising wastage. Always cut from the foil faced barrier side of the material.

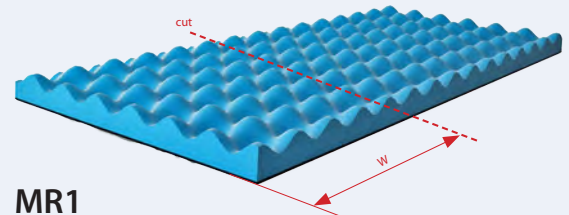
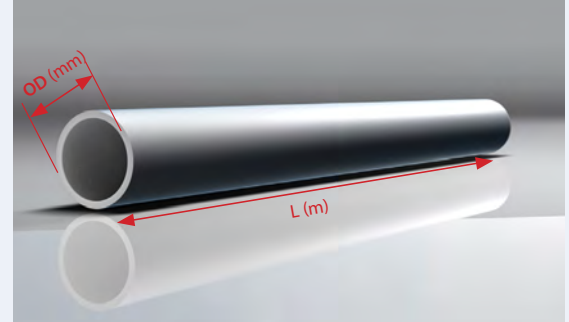

MR1



ABOUT 'TAPE ALR' - REINFORCED ALUMINIUM INSULATION JOINING TAPE:

Pyrotek can provide on request, 'Tape ALR' - a high quality self-adhesive insulation joining tape. This pressure-sensitive reinforced aluminium foil tape is designed to serve as a joining or covering tape for Pyrotek's 'Soundlag' and other foil-faced products.

HOW TO APPLY INSULATION JOINING TAPE (see images 1 to 4)

1. Tape ALR is easy to tear by hand.
2. Remove the release liner backing
3. Position tape centrally over the sections to be joined and firmly press along the entire tape surface.
4. Wipe or rub with firm pressure across the tape with a cloth or blade to smooth out any air bubbles or buckles.

Do not over-stretch the tape when applying as this will create buckles and voids in the contact area.

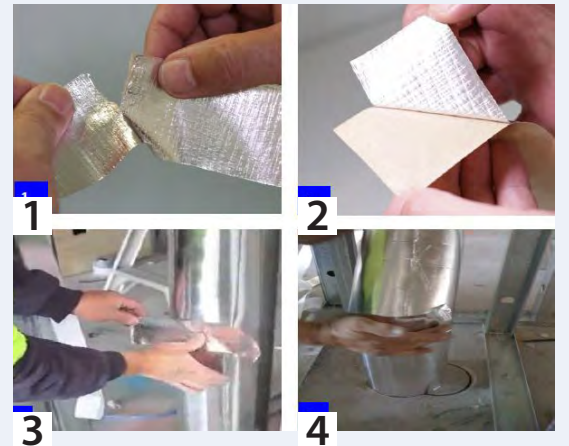

TREATMENT OF JOINTS ON STRAIGHT PIPE SECTIONS

- All joints along longitudinal pipe sections must be fitted with an overlap of adjoining material segments. Overlapped sections must then be taped and sealed with 'Tape ALR' or equal.
- A strip of 30 mm foam can be removed along one or both edges as required to provide for an overlap at joints. (See OVERLAPPING images)
- Images show insulation material segments with foam removed being overlapped at joints.
- Joints overlapped with foam removal provide a smooth surface.

OVERLAPPING

Images (left to right) show the removal of foam *before* being overlapped at joints. Joints overlapped without foam removal provide a smooth surface.

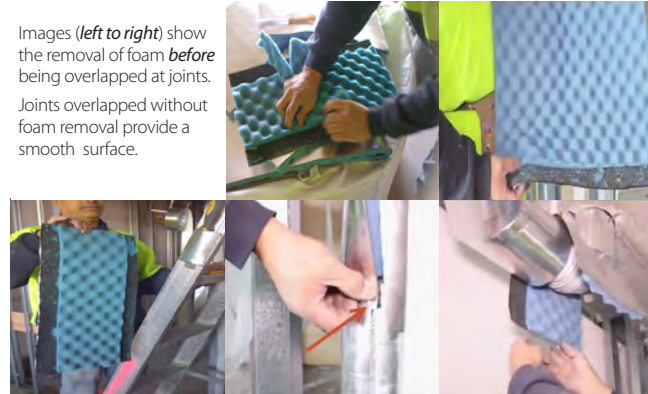

LAGGING A STRAIGHT PIPE SECTION

A diagrammatic representation of Soundlag lagged to a straight pipe section

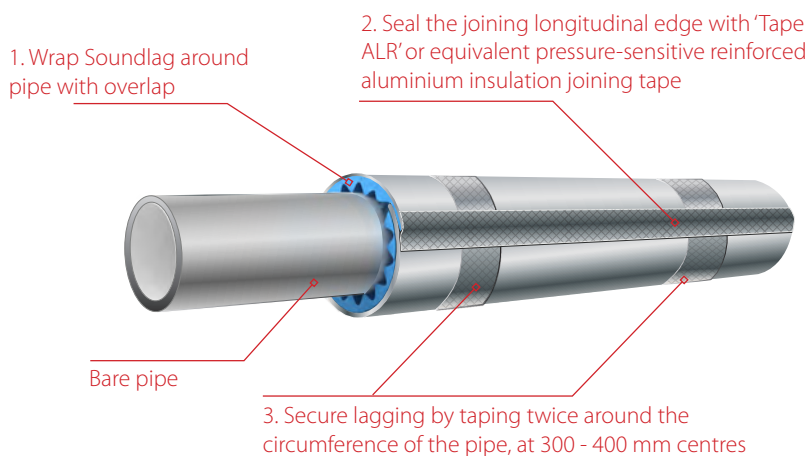

TEST TO CHECK FOR A TIGHT SEAL OF JOINTS

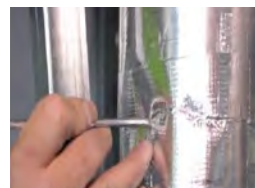

Overlap

A correctly sealed joint will NOT allow the metal object to pass through the tape.

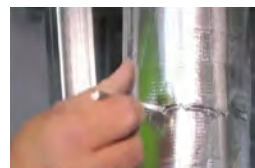

No Overlapping

An incorrect butt joint or no overlap will allow the metal object to pass through the tape and lagging.

Soundlag on a straight pipe section *in situ*



Wrap each segment with an overlap



Use small tape patches to secure the wrap and position firmly around the pipe



Tape along the longitudinal overlapped length



Continue lagging adjoining pipe area with the recommended overlap and joint treatment



Tape all joints and edges for a tight seal

The following table is an indicative measure of Soundlag 4525C (1.35 X 5 m roll) coverage on straight pipe sections. The calculation includes an overlap as stated in the formula.

PRODUCT SPECIFICATIONS

Nominal Inside Pipe Diameter (mm)	Outside Pipe Diameter (mm)	Actual Cut Length -Wrapping Width- (mm)	Pieces Per Roll (1.35 x 5 m roll) Units	Coverage of Straight Pipe Section (Lineal metres)
32	36	260	19	25.5
40	43	280	17	23
50	56	320	15	20
65	69	360	13	17.5
80	83	405	12	16
100	110	500	10	13.5
150	160	650	7	9.5
225	250	930	5	7
300	316	1135	4	5
375	401	1400	3	4

NOTE: All information above only serves as a general guideline. Different applications can vary case-by-case. Please contact your local Pyrotek representative for more information.

Brochure



acoustic pipe and duct lagging

SOUNDLAG



BUILDING - INDUSTRIAL - TRANSPORT - MARINE - OIL & GAS



SOUNDPROOFING SOLUTIONS FOR ALL INDUSTRIES
pyroteknc.com

Pyrotek



ACOUSTIC PIPE AND DUCT LAG

Soundlag® is a range of high-performance acoustic lagging products developed by Pyrotek to reduce waste water noise from pipes, fan housings, and ducting within building and industrial environments. Soundlag is a composite product consisting of reinforced foil faced mass loaded vinyl (MLV) and a decoupling layer of either foam or glass wool.

No. 1 lagging product
choice for leading Hydraulic
and Acoustic Engineers

The highly flexible and dense MLV layer provides outstanding sound reduction, whilst the decoupling foam breaks the vibration path between the substrate and the mass barrier. The aluminium foil covering offers flame-resistant properties, while also providing a seamless bonding surface when used with Pyrotek's Tape ALR.

Unlike other noise barriers, Soundlag's unique flexibility can be easily cut and formed to any shape or bend. The pliability achieves an excellent acoustic seal by eliminating potential flanking noise through the joints and overlaps.

Australian made, Soundlag has been independently tested, backed with over 20 years manufacturing. Maintaining consistent performance and trustworthy quality, Soundlag guarantees quieter ducts and pipes.

FOIL FACING OPTIONS

Alternative colour options to the reinforced aluminium facing are black and white foil. These anti-glare foil colours are suitable for exposed ceiling spaces.

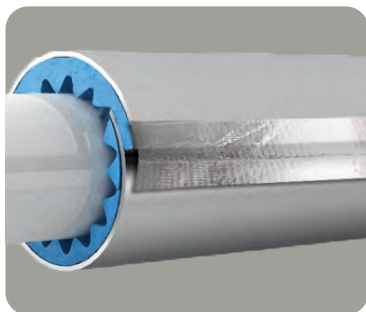

Aluminium

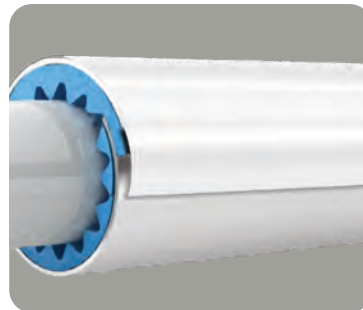

White

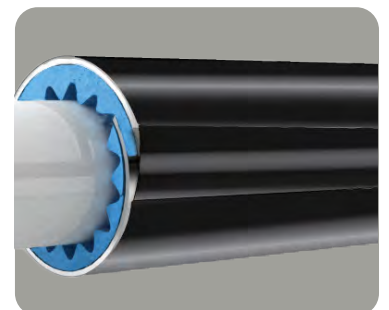

Black

Reduce waste water noise by 25 dB(A)



Soundlag 4525C meets Rw+Ctr 40 for habitable and Rw+Ctr 25 for non-habitable rooms

BCA Section F5.6 compliant Non-habitable room and BCA Section F5.6 compliant Habitable room



Low Noise Pipe

Does not meet BCA for non-habitable areas where penetrations exist



Lagged PVC Pipe (Soundlag)

Suitable for BCA compliance for non-habitable areas where penetrations exist



Lagged PVC Pipe (Soundlag)

Suitable for BCA compliance (habitable) with 10 mm plasterboard

Proven to achieve better noise reduction results than low noise pipes

Soundlag, quieter than Low Noise Pipes

Low Noise Pipes (LNP) is 4-5 dB(A) noisier than lagged PVC

FEATURES & BENEFITS

- Reduces noise by up to 25 dB(A)
- Easy to cut, wrap and install
- Low spread of flame surface
- Contains no ozone-depleting substances
- Free from odour producing oils and bitumen
- Accredited to ISO 9001 quality management standard
- Australian made
- Sold in over 15 countries
- Over 25 years of product development
- 25% higher acoustic performance than competitors
- Independently tested by leading acoustic consultants
- Will not delaminate or crack when wrapped around pipes and bends



○○○○○ Reduce breakout noise from waste water pipes and ductwork within commercial and residential buildings

HOW TO MEASURE AND CUT MATERIAL

Example for Straight Pipe Sections

Measure the length (L) and outside diameter (OD) of the pipe requiring lagging.

Apply the following formula to calculate and cut the required wrapping width (W) of Soundlag. The formula allows for a 3 to 5 percent overlap.

$$W = \pi \times (OD + (2 \times T)) \times P$$

OD = outside diameter of the pipe

P = percentage overlap (1.03 to 1.1)

$\pi = 3.14$ (pi)

T = total thickness of acoustic insulation (allow 20% compression on thickness when using convoluted foam or fibreglass decoupling layers)

Mark the calculated width (W) along the length of the roll and cut material with a retractable knife or scissors.

Please refer to install guide for more details

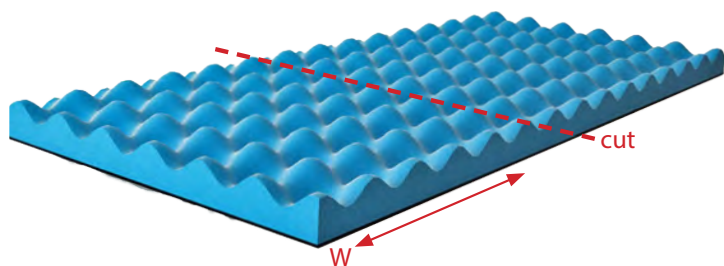
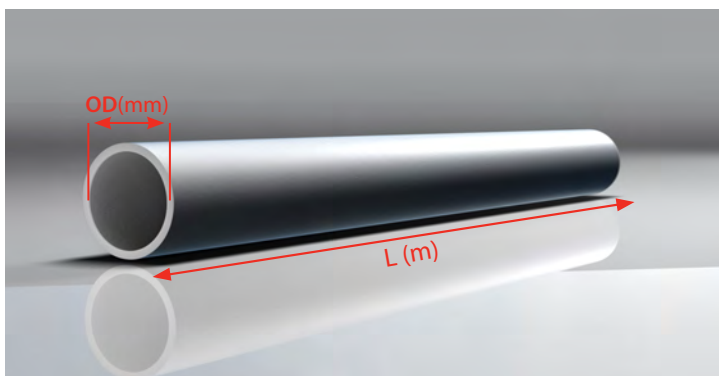

Pyrotek recommends an overlap at all joints to eliminate potential flanking noise. The removal of foam before overlapping at joints will provide a better acoustic seal and smooth surface

Soundlag® is easily cut with a knife or scissors, then simply wrapped around the pipe using high quality aluminium tape. Remember to always cut from the foil faced barrier side of the material.



90° bend

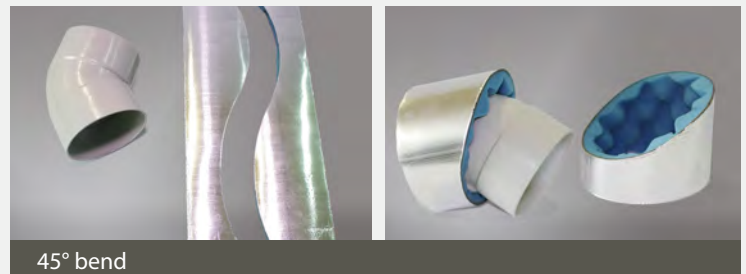

45° bend



Y junction

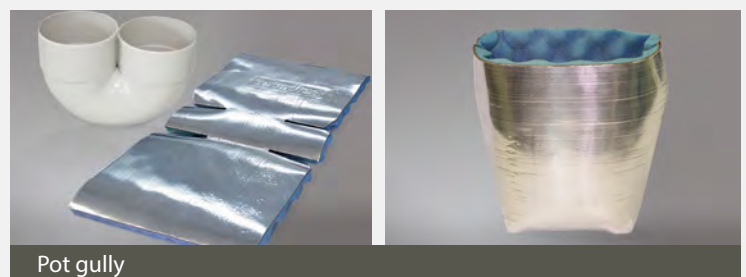

Pot gully

Precut pieces are available, speak with your Pyrotek representative for more information

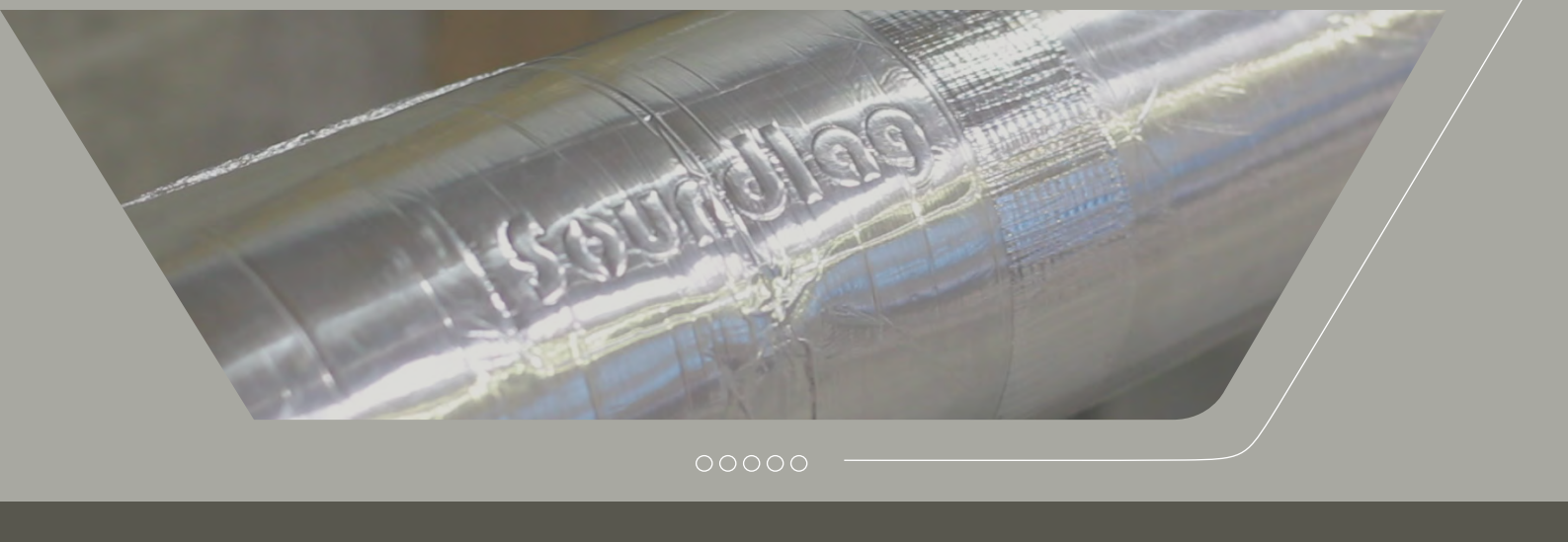

ACOUSTIC PERFORMANCE

Working with acoustic and hydraulic consultants and test facilities, Pyrotek has designed and tested systems to achieve a high level of noise reduction for all plumbing and duct situations.

Soundlag has been acoustically tested in field and independent laboratories.

PROVEN QUALITY

With over 20 years of manufacturing, Soundlag has proven not to crack, delaminate or cause plasticised tape failure - one of the reasons why it is the leading choice for many acoustic consultants, architects and consulting engineers worldwide.

Soundlag carries a ten year warranty and is easily recognised by the 'Soundlag' embossing.

SOUNDLAG®

Low VOC emission
exceeds Green Star rating
of $<0.5 \text{ mg/m}^2/\text{h}$

10
YEARS

MANUFACTURER'S
WARRANTY

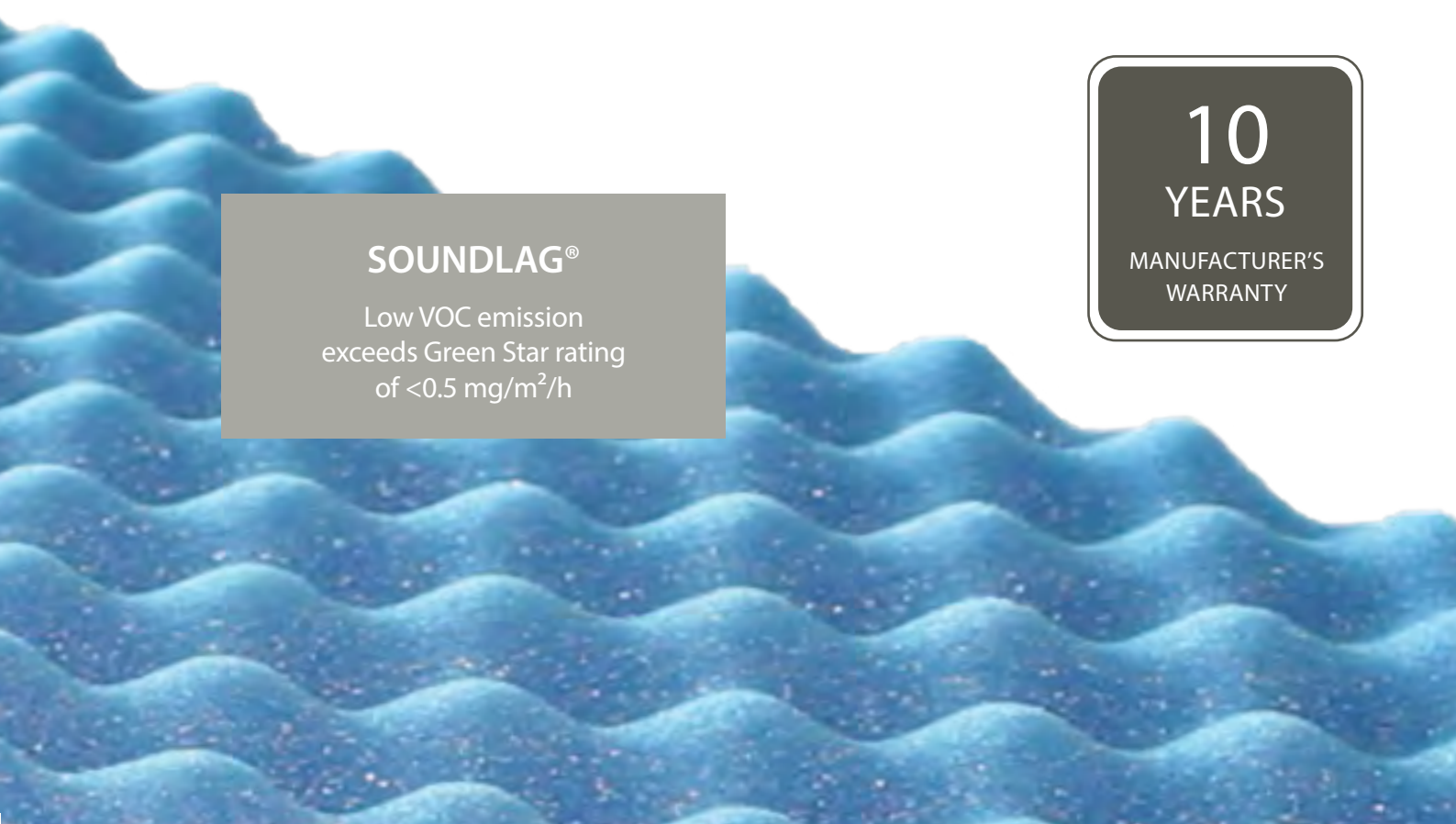



80+ Locations in 30+ countries

- six research and development centres
- five engineering centres
- global headquarters in Spokane, Washington, USA



Please visit our website at pyroteknc.com for additional information including:

- Specification
- Technical Data Sheet
- Installation Guides
- Case Studies

Pyrotek endorse forest sustainability and the preservation of natural environment. We procure the highest quality materials from suppliers who hold FSC (Forest Stewardship Council) Certification and PEFC (Programme for the Endorsement of Forestry Certification) amongst other certification programmes.

Caveats: Specifications are subject to change without notice. The data in this document are typical of average values based on tests by independent laboratories or by the manufacturer and are indicative only. Materials must be tested under intended service conditions to determine their suitability for purpose. The conclusions drawn from acoustic test results are as interpreted by qualified independent testing authorities. Nothing here releases the purchaser/user from responsibility to determine the suitability of the product for their project needs. Always seek the opinion of your acoustic, mechanical or fire engineer on data presented by the manufacturer. Due to the wide variety of individual projects, Pyrotek NC is not responsible for differing outcomes from using their products. Pyrotek disclaims any liability for damages or consequential loss as a result of reliance solely on the information presented. No warranty is made that the use of this information or of the products, processes or equipment to which this Information Page refers will not infringe any third party's patents or rights. DISCLAIMER: This document is covered by Pyrotek standard Disclaimer, Warranty and © Copyright clauses. See www.pyroteknc.com/disclaimer.

SOUND ABSORBERS

Reapor® is constructed from small aerated granules made from recycled glass. The granules are fused together through a patented high temperature sintering process to form a hard, **lightweight**, fibre-free, **non-combustible** stone-look panel that can be used indoors and outdoors. The unique material is highly porous, absorbing noise both between and within the granules.

REAPOR®

Reapor® panels are simple and easy to install using recommended adhesives (refer to the Reapor® Installation Guide for details). The panels can be cut, drilled and routed using standard wood working tools, enabling easy installation around obstacles.

The panels are suitable for use outdoors. Wet panels will drain freely and dry in the sun.

Reapor® is a registered trademark of Liaver used with permission by Pyrotek as distributors.

Features

- Non-combustible
- Lightweight and fibre free
- Easy to cut, drill and route using standard wood working tools
- Resistant to weather, water and UV exposure over an extended period of time
- Natural 'stone-like' appearance to suit indoor and outdoor designs

Application

- Interior walls and ceilings inside buildings
- Outdoor rooftop noise enclosure for air conditioning condenser units
- Plant rooms or elevator shafts
- Exhaust stack internal lining



Standard size: 50 x 625 x 625 mm
Custom sizes available depending on MOQ

VOC STATEMENT

Reapor® does not contain any Volatile Organic Compounds (VOC) when evaluated to the differing definitions as applied under the Australia National Pollutant Inventory, the EU Council Directive 1999/13/EC or the USA EPA Regulation 40CFR 51.100(s). This product can be classed as low VOC-emitting. The material emissions are less than the threshold of 0.5 mg/m²/hr as specified in Green Building Council of Australia 'Green Star' credit IEQ-13. Formaldehyde compound emission rate is less than the threshold of 0.1 mg/m²/hr as specified in 'Green Star' credit IEQ-14.

Technical Datasheet



REAPOR®

eco-friendly sound absorber for challenging environments

Reapor® acoustic panels are high-performance noise absorbers that look like cut stone.

It is constructed from small aerated granules made from recycled glass. The granules are fused together through a patented high-temperature sintering process to form a hard, lightweight, fibre-free, non-combustible stone-like panel that can be used indoors and outdoors. The unique material is highly porous, absorbing noise both between and within the granules.

Reapor® panels are simple and easy to install using recommended adhesives (refer to the Reapor® Installation Guide for details). The panels can be cut, drilled and routed using standard woodworking tools, enabling easy installation around obstacles.

The panels are suitable for use outdoors. Wet panels will drain freely and dry in the sun; however, this may result in efflorescence where crystalline salts are deposited on the surface of the panel. Efflorescence will not affect acoustic performance. If efflorescence does occur, the salts may be removed using commercial efflorescence cleaners. *(Please refer to the Reapor® Installation Guide for more information).*

VOC STATEMENT

Reapor® does not contain any Volatile Organic Compounds (VOC) when evaluated to the differing definitions as applied under the Australia National Pollutant Inventory, the EU Council Directive 1999/13/EC or the USA EPA Regulation 40CFR 51.100(s). This product can be classed as low VOC-emitting. The material emissions are less than the threshold of 0.5 mg/m²/hr as specified in Green Building Council of Australia 'Green Star' credit IEQ-13. Formaldehyde compound emission rate is less than the threshold of 0.1 mg/m²/hr as specified in 'Green Star' credit IEQ-14.

SPECIFICATIONS

Colour	Light grey
Available	50 x 625 x 625 mm
	25 x 625 x 625 mm*
	25 x 625 x 1200 mm*
	50 x 625 x 1250 mm*
	63 x 625 x 625 mm* (*Sold FCL only)
	Custom sizes available depending on MOQ

25 mm thick Reapor® does not feature chamfered edges.

Reapor® is a registered trademark of Liaver used with permission for Pyrotek as distributors.



applications

- Rail and motorway tunnels, vent shafts and noise barriers
- Outdoor cafes, bars and restaurants
- Interior walls and ceilings of offices, retail spaces, hospitals, schools and aged care facilities
- Fire exits and stairwells
- HVAC and genset plant rooms
- Industrial noise enclosures
- Shooting ranges

features

- Resists weather, water and UV exposure over an extended period
- Non-combustible
- Exceptionally high NRC of 0.95 (50 mm thick panel)
- Easy to cut, drill and rout using standard woodworking tools
- Natural 'stone-like' appearance to suit indoor and outdoor designs
- Made from recycled glass
- Lightweight
- Fibre free



PRODUCT SPECIFICATIONS

Product name	Thickness (mm)	Panel size			Density (kg/m ³)
		Length (mm)	Width (mm)	Approximate weight (kg)	
Reapor® 25/625625	25	625	625	2.6	270
Reapor® 25/1200625		1200		5.1	
Reapor® 50/625625	50	625		5.3	
Reapor® 50/1250625		1250		10.5	
Reapor® 63/625625	63	625		6.6	

Tolerances: Dimensions ± 1 mm, Density: $\pm 10\%$. 25 mm thick Reapor® does not feature chamfered edges.

MATERIAL PROPERTIES

Test method	Property	Report	Results	
DIN 196-1	Compressive strength	B 12.16.103.01	1.46 N/mm ² ($\pm 10\%$)	
	Flexural strength		0.53 N/mm ² ($\pm 10\%$)	
DIN 1607	Tensile strength		0.14 N/mm ² ($\pm 10\%$)	
DIN 1048	Dynamic modulus of elasticity		833 N/mm ² ($\pm 10\%$)	
DIN 52612	Thermal conductivity	1254P41/P	0.077 W/mK	
AS/NZS 3000	Electrical conductivity	9765	Non-conductive	
EN 13501-1	Fire classification of construction products and building materials	KB 3.1/11-121-3	Non-combustible	
DIN 4102	Fire resistance	16-900 9171 002-1		
AS 1530.1 / ISO 1182	Fire resistance	FNC11639		
AS 1530.3	Method for fire tests on building materials, components and structures	16-000832	Ignitability	0
			Spread of flame	0
			Heat evolved	0
			Smoke developed	1
ISO 5660 / AS/NZS 3837	Building code compliance	FH 5357-01-2	NCC	1
			NZBC	1-5
ASTM D5116	Total volatile organic compound emission rate	CV130829	0.026 mg/m ² /hr	
	Formaldehyde compound emission rate		<0.005 mg/m ² /hr	
EN 1793-1	Intrinsic sound absorption performance of roadside noise reducing devices	P-BA 235/2020	DL _a 11 dB Category A3	
Pyrotek Pull Test Method	Adhesion of Reapor to concrete substrate using recommended fixing methods and adhesive	13121BDA	> 3.7 kN/m ² (> 380 kgf/m ²)	

ACOUSTIC PERFORMANCE

Frequency (Hz)	Reapor 25 mm	Reapor 50 mm	Reapor 63 mm
100	0.04	0.08	0.16
125	0.06	0.10	0.23
160	0.08	0.29	0.38
200	0.13	0.37	0.53
250	0.13	0.57	0.81
315	0.23	0.92	1.02
400	0.35	1.12	1.13
500	0.52	1.23	1.13
630	0.67	1.21	1.07
800	0.90	1.02	0.97
1000	1.05	0.98	0.92
1250	1.13	1.03	0.98
1600	1.05	1.09	1.04
2000	0.97	1.08	1.02
2500	0.93	1.04	1.03
3150	0.98	1.05	1.01
4000	0.99	1.04	1.08
5000	0.94	1.04	0.95
NRC	0.65	0.95	0.95
SAA	0.67	0.97	0.97
α_w	0.45 (MH)	0.90	1.00

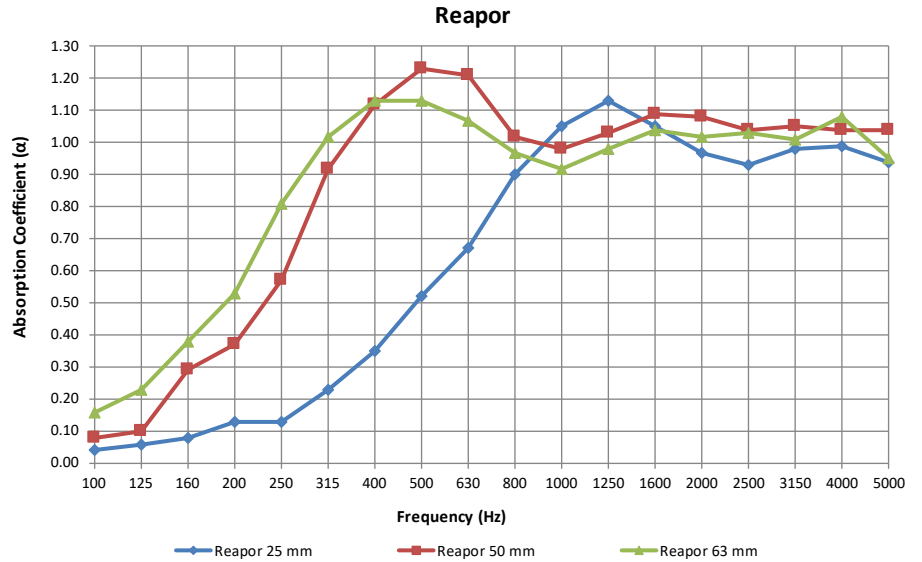

Tested to ISO 354:2003 at Vienna Experimental and Research Institute (Austria) & CSIRO (Australia)
 Report Numbers: MA 39-VFA 2007-1277.01, AC186-01-1 & P-BA 195/2017e

For further information and contact details, please visit our website pyroteknc.com

Caveats: Specifications are subject to change without notice. The data in this document is typical of average values based on tests by independent laboratories or by the manufacturer and are indicative only. Materials must be tested under intended service conditions to determine their suitability for purpose. The conclusions drawn from acoustic test results are as interpreted by qualified independent testing authorities. Nothing here releases the purchaser/user from responsibility to determine the suitability of the product for their project needs. Always seek the opinion of your acoustic, mechanical and fire engineer on data presented by the manufacturer. Due to the wide variety of individual projects, Pyrotek is not responsible for differing outcomes from using their products. Pyrotek disclaims any liability for damages or consequential loss as a result of reliance solely on the information presented. No warranty is made that the use of this information or of the products, processes or equipment to which this Information Page refers will not infringe any third party's patents or rights. DISCLAIMER: This document is covered by Pyrotek standard Disclaimer, Warranty and © Copyright clauses. See pyroteknc.com/disclaimer.



PRODUCT SPECIFICATIONS

Product Name	Adhesive type	Colour	Packaging	Weight	Mixing Ratio (Water to adhesive)
Pyrotek CB Adhesive	Cementitious	White	Plastic lined paper sacks	20 kg	1:3

MATERIAL PROPERTIES

Coverage m ²	Application
5 - 6	Using 12 x 12 mm trowel
10 - 12	Using 6 x 6 mm trowel

Standard AS ISO 13007	
C2	> 1.00 MPa
E	open time
T	Thixotropic
S1	> 2.5 mm deflection over 300 mm

Properties	Result
Tensile strength	> 2.0 MPa
Tensile strength, immersed material for 21 days	> 1.0 Mpa
Tensile strength, 14 days heat aged	> 1.5 MPa
Transverse Deformation	> 3.5 mm
Compressive strength	> 20 MPa
VOC content	< 1 g/L

Properties	Time
Open time	20 min
Pot life	1 hr
Initial set	6 hr
Foot traffic	24 hr
Heavy traffic	72 hr

Note: Above specification is for material at 20 °C.

For further information and contact details, please visit our website pyroteknc.com

Caveats: Specifications are subject to change without notice. The data in this document is typical of average values based on tests by independent laboratories or by the manufacturer and are indicative only. Materials must be tested under intended service conditions to determine their suitability for purpose. The conclusions drawn from acoustic test results are as interpreted by qualified independent testing authorities. Nothing here releases the purchaser/user from responsibility to determine the suitability of the product for their project needs. Always seek the opinion of your acoustic, mechanical and fire engineer on data presented by the manufacturer. Due to the wide variety of individual projects, Pyrotek is not responsible for differing outcomes from using their products. Pyrotek disclaims any liability for damages or consequential loss as a result of reliance solely on the information presented. No warranty is made that the use of this information or of the products, processes or equipment to which this Information Page refers will not infringe any third party's patents or rights. DISCLAIMER: This document is covered by Pyrotek standard Disclaimer, Warranty and © Copyright clauses. See pyroteknc.com/disclaimer.



Installation Guide



REAPOR®

This installation guide provides recommendations to maximise the service life of Reapor® applications.

KEY INSTALLATION REQUIREMENTS

Reapor® panels are simple and easy to install using recommended brackets and adhesives. The panels can be cut, drilled and routed using standard woodworking tools, to enable easy installation around obstructions.

All substrates must be clean and free from laitance, curing compounds, dirt, dust, grease, oil and any other contaminants that may inhibit bond.

Reapor should be installed on dry walls and ceilings. Panels are not recommended for installation on retaining walls or below damp courses.

To prevent rainwater migration to the rear of the panels in outdoor applications, the panels should be installed with either flashing/capping installed over the top panels/wall (eg. COLORBOND® steel) or panels can be recessed into the pre-cast concrete walls. The recommended recess is 70 to 80 mm (2.8 to 3.1 in) to cater for the panel, adhesive layer and ~25 mm (1 in) soffit/drip edge above the top acoustic panel.

The bottom panels should be installed with a free drip edge to enable Reapor to drain freely and avoid wicking water up from pavements etc.

Reapor® is quickly and easily installed to horizontal and vertical surfaces.

TUNNEL APPLICATION

To ensure a smoother installation for tunnel applications, we recommend using 625 x 208 mm panels.



applications

- Interior walls and ceilings of offices, retail space, hospitals, schools and aged care facilities
- Walls of railway and motorway tunnels, vent shafts and exits
- Applications requiring high fire ratings
- Airports, stations, and carparks
- Machinery or industrial enclosures
- HVAC, plant rooms, and substations
- Exit ways, smoking areas, stairwells and drive-through areas
- Road barriers, exterior plant fences and sound barriers

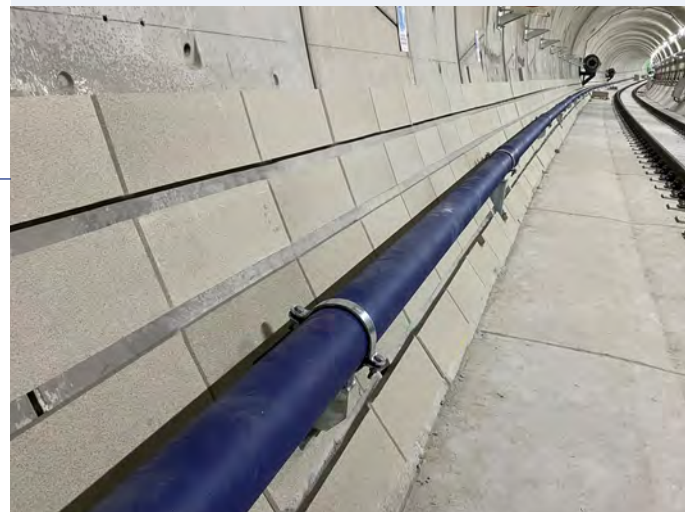

Reapor 625 x 208 panels installed in tunnel application

Reapor® is a registered trademark of Liaver used with permission for Pyrotek as distributors.



INSTALLATION USING ADHESIVE AND MECHANICAL FIXING

CONCEALED FIXING

1. Approved Pyrotek adhesive (Fixseal MS15, Fix8, Pyrogrip PU) should be used to fix RB brackets (see RB bracket drawings below) and Reapor panels to rigid substrates, such as concrete, pre-fabricated walls, block work, timber, reinforced fibre cement boards or sheet metal.
2. When applying to solid surfaces (cementitious products) a Ramset / Hilti or equivalent gun with 25 mm stainless steel drive pins / nails can be used to fix RB Brackets only.
3. All substrates must be clean and free from laitance, curing compounds, dirt, dust, grease, oil and any other contaminants that may inhibit bond.
4. All substrates should be washed with clean water and thoroughly dry before the application of the adhesive.
5. If in doubt, prepare the substrate using a pressure washer to expose the fine aggregates in the matrix of the concrete as this ensures a clean substrate.
6. Consideration should be given to the transfer of load on horizontal installation - panels must not bridge expansion joints
7. Use a straight edge support to ensure a level plane is set for the RB Base Brackets.
8. Apply 3 grams of adhesive to each RB Base Bracket and secure in place allowing the straight edge to support brackets during curing process. Allow adhesive to cure for 2-3 hours before proceeding with Reapor installation.
Alternatively secure each bracket with 25 mm stainless steel drive pins / nails (cementitious substrates only)
9. Two RB Base Brackets are required for each Reapor panel. Each bracket should be a minimum of 90 mm from each panel edge - allowing for minimum 325 mm centre space between the brackets of each panel.
10. Apply 3 grams of adhesive to upward facing base of fixed bracket before placement of Reapor panel - this will ensure better adhesion.
11. **For 625 x 625 panels** apply adhesive to outer edge of panel (6 x 9 grams per blob) - ensure glue is approx 100 mm from the edges (see image 1).
12. **For 625 x 208 panels** apply adhesive to outer side of panel (2 x 8 grams per blob) - ensure glue is approx 100 mm from the edges (see image 2).
13. Slightly angle tile to substrate with lower back edge resting on RB Base Bracket (see image 3). Secure in place pushing firmly against substrate.
14. Apply 3 grams of adhesive to back and base of RB Spacer bracket, Center bracket or Top bracket and secure to top edge of panels (two brackets for each panel) - ensure adhesive is applied between bracket and panel (see image 4).
15. Secure bracket in place by pressing into Reapor panel and gently hammering in place with small rubber mallet.
16. Each Reapor tile should be pierced with a total of four spikes - two along the lower edge and two along the upper edge.
17. Stains or debris on the surface of Reapor® can be removed by lightly sanding.
18. Refer to Mechanically Fixing drawing for flat surfaces (below) for installation instructions using RB Brackets.

1



Apply adhesive around the edges of the tile only

2



Apply adhesive to the side of the tile only (625 x 208 panels)

3



Apply the tile to the substrate with firm pressure

4

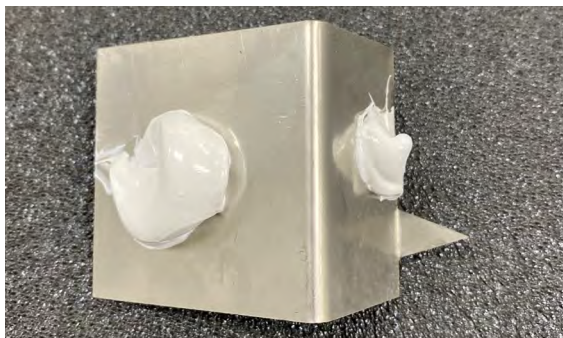

RB Centre Bracket with adhesive applied



RB BRACKET DRAWINGS (brackets made from 316 stainless steel)

Mechanical fixing using RB Centre Brackets

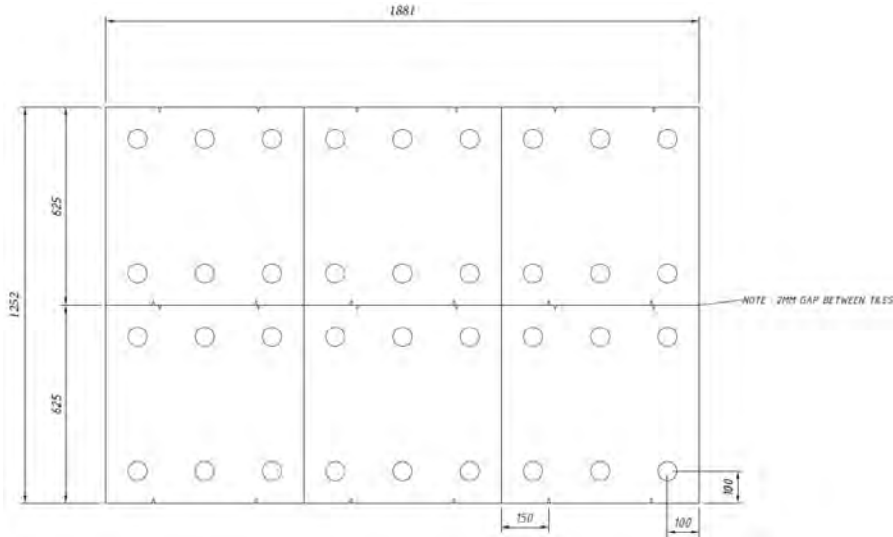

1

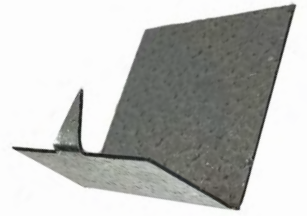

RB Base Bracket

2



RB Spacer Bracket

Mechanical fixing using RB Spacer Brackets

(Example of Installation for tunnels and curved surfaces)

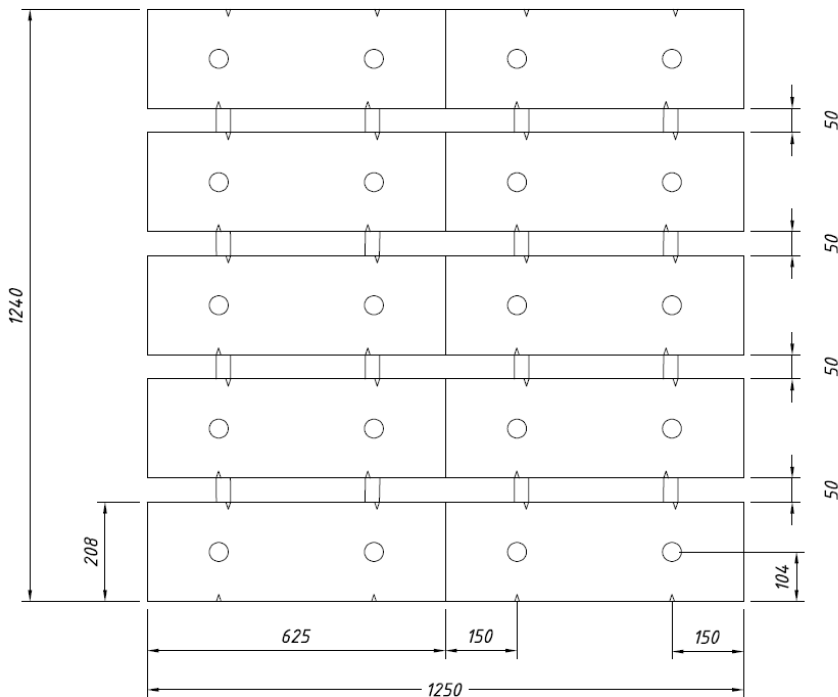

3

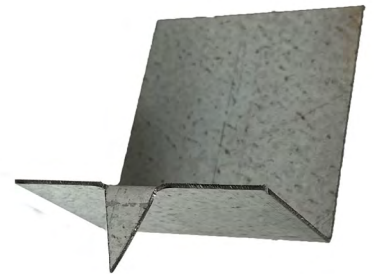

RB Top Bracket

4

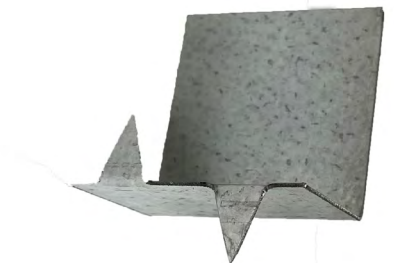

RB Centre Bracket

Reapor Brackets are supplied in stainless steel.
Minimum order quantities apply

KEY	
	ADHESIVE
	RB SPACER BRACKET
	RB BASE BRACKET
	RB TOP BRACKET
	RB CENTRE BRACKET



INSTALLATION USING ADHESIVE AND MECHANICAL FIXING cont.

UNCONCEALED FIXING

This method is recommended for high wind load and elevated areas

For unconcealed mechanical fixing - stainless steel or plastic pins (UV resistant) can be used.

1. Follow mechanical fixing steps as above for recommended adhesive and Reapor installation guide.
2. Once panel has been applied to substrate, drill through the centre of the panel and approx 30 mm into the substrate using an 8 mm drill bit (see image 1).
3. Insert 8 mm x 80 mm pin into pre-drilled hole (see image 2).
4. Use a hammer to gently tap the pin into the substrate (see image 3)
5. Ensure the pin is flush with Reapor surface (see image 4)
6. It is recommended to paint pin heads after installation to prevent corrosion and UV oxidation caused by the elements.

This installation section is for general advice only.

If you feel your application is unique please contact your Pyrotek representative for more information.

1



Drill into the centre of Reapor

2



Gently insert pin

3



Gently hammer the pin in place

4

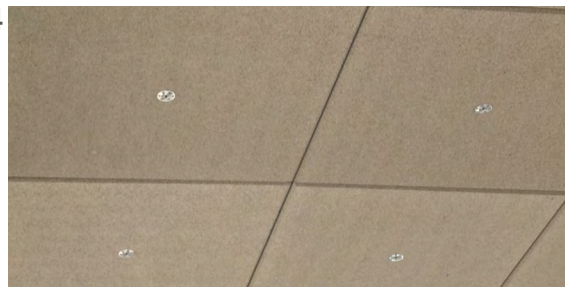

Completed overhead installation

GENERAL MAINTENANCE

Weathering

Reapor® is a porous stone-like material with a consistent colour and texture through the tile. Reapor® will weather and age naturally in the elements in a similar way to soft natural stones.

In outdoor applications, Reapor® may show signs of efflorescence, a temporary condition which can be removed by brushing or rinsing with a hose. In most cases, over time rainwater steadily removes the deposit leaving the original colour of the panel unharmed.

Ensure adequate drainage is present so that efflorescence deposits do not occur as a result of pooled runoff water.

Efflorescence does not affect the quality, acoustic performance or functionality of Reapor®.

Care, Repair and Maintenance

- Replace any cracked or broken tiles.
- Clean any debris to maintain the free drip edge and ensure the damp course is not breached.
- Regularly inspect flashing to ensure it remains functional.
- Clean off any efflorescence by first dry brushing off build up of deposits with brush or tools. The surface can also be sanded to remove surface stains or other marks (you can use a piece of Reapor® as a sanding block - ie Reapor on Reapor).
- If further staining is visible, consider hosing down, or using mild soapy water to rinse. Efflorescence remover is recommended only for very stubborn areas.

DETAILING

Cutting, Routing and Rebating

Reapor® tiles can be easily processed, routed, rebated or hand sawn to any shape such as creating grooves and channels.

- A circular saw fitted with a continuous rim diamond tipped masonry blade can be used for cutting in large projects.
- Consideration should always be made for proper dust control and ensure suitable PPE is equipped before work.

(Please refer to the Reapor® SDS for further information)

Treatment of Perforations

Adequate flashing should be incorporated to discourage and deflect water away when Reapor® tiles are drilled for cabling and pipe access



Reapor resists weather, water and UV exposure



Tunnel application - Reapor installed on the wall



Regularly inspect flashing for functionality



Reapor can be routed to allow cable access

Please contact Pyrotek® for further information or detailed advice on your specific application.

Brochure



SOUND ABSORBER FOR CHALLENGING ENVIRONMENTS

REAPOR®



SOUNDPROOFING SOLUTIONS FOR ALL INDUSTRIES
pyroteknc.com

Pyrotek.

- Exceptionally high Noise Reduction Coefficient (NRC)
- Unique, non-combustible glass-based material
- No smoke emissions
- Weather, water and UV resistant

SOUND ABSORBER FOR CHALLENGING ENVIRONMENTS

Reapor® panels are made from recycled glass granules, using a patented German process. The granules are fused together to form stone-look panels that can be used both indoors and outdoors. Reapor panels are hard, lightweight and fibre-free. The unique material absorbs noise both between and within the glass granules, resulting in exceptionally high noise reduction.

Reapor has the pleasant appearance of cut stone. Made from recycled glass, the panels are lightweight and durable. Reapor is easily installed and maintained, has no VOC emissions and is durable in both indoor and outdoor applications.

Reapor has a wide range of applications where effective noise reduction is required in outdoor and indoor areas – especially those areas with high humidity or fire concerns. Unlike traditional porous or open-cell materials, Reapor will not disintegrate with contact of water or moisture. Reapor panels are non-combustible and binder free.

FEATURES

- High sound absorption
- Non-combustible
- Fibre-free
- Rigid and durable
- Made from recycled materials
- Easily worked
- Lightweight
- Non-toxic, volatile organic compound free
- Quick and simple to install
- Easily maintained and cleaned
- Simple to repair
- Safe to use
- Endorsed and tested by leading acoustic consultants and engineers



FIRE SAFETY (SMOKE AND VOLATILE FREE)

Around the world, building codes are changing to reflect the increasing understanding of fire hazards. Materials that utilise fire retardants may slow the spread of fire but not reduce smoke production. The demand for virtually non-combustible materials is on the rise. Reapor has achieved a non-combustible rating, with no smoke emissions. When exposed to fire or flames, Reapor will not emit any toxic fumes or volatiles, making its installation a fire-safe way of controlling unwanted noise.

INSTALLATION

Reapor panels can be cut, drilled and routed using standard woodworking tools. This enables easy installation around obstacles, and the production of decorative shadowing effects. Various install methods are available and can be found in Installation Guide located on our website.



Reapor can be easily routed, cut and shaped

Reapor is suitable for both indoor and outdoor applications where exceptional noise reduction is required

PRODUCT CONSTRUCTION

Reapor panels are made using a unique process. Expanded glass granulate is mixed and formed. The glass granules are then sintered at temperatures of 750 °C - 900 °C this then cures the green panel. This process ensures that there are no Volatile Organic Compounds (VOCs) that can later be released, and that the panels can not break down over time through binder failure.

WEATHER, MOISTURE AND CONTAMINATION

With its fused glass granule construction, Reapor is naturally resistant to both moisture and sunlight. In these conditions, other acoustic materials need elaborate protection, often adversely affecting acoustic performance. But Reapor requires no such protection, and if installed correctly and with adequate flashing, will last indefinitely. If exposed to damp conditions, a sodium residue known as efflorescence may appear on the surface. However, this does not affect the product's performance and can be easily washed off.

ACOUSTIC TESTING

Reapor has exceptional acoustic performance for its thickness. This is due to the numerous glass granules which act as individual, tiny sound absorbers. When tested independently to ISO standard, Reapor has an NRC of 0.95 at 50 mm thickness.

EDGE DETAIL

Reapor is available with chamfered or square edge finishes. This flexibility allows Reapor panels to seamlessly enhance your desired architectural appearance.

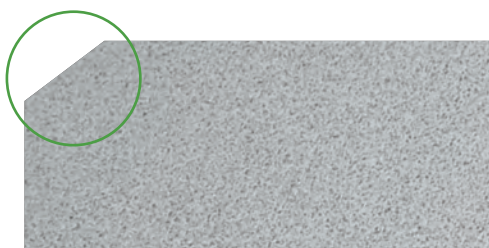

Chamfered edge



Square edge

APPLICATIONS

- Rail tunnels and rail noise barriers
- Tunnels, vents and exits
- Road side noise barriers
- High fire safety areas
- Plant rooms
- Substations and enclosures
- Indoor swimming pool and spa areas
- Exit ways, stairwells and smoking areas
- Cooling towers
- Restaurants and cafés
- Parking exits



Rail tunnels



Cooling towers and HVAC



Restaurants, cafés



Outdoor areas - including Power generators, air conditioning enclosures

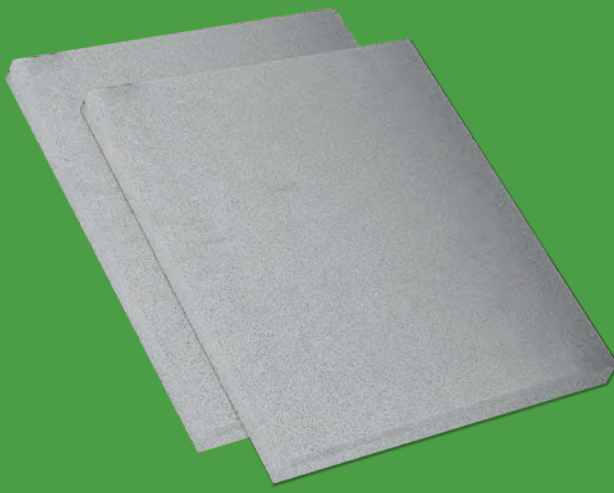

FREQUENTLY ASKED QUESTIONS

(Please refer to the installation guide and TDS on our website for more information).

DOES IT HAVE BINDERS?

Reapor does not use binders in its manufacture. Therefore, there are no VOCs to be released and there is no binder that could break down over time. The additional benefit is no smoke or volatiles released when exposed to fire or flames.

DOES IT HAVE POTENTIAL FOR MOULD GROWTH?

With no organic substances for bacteria to live on, Reapor does not support mould growth. However, if mould growth were to occur through a build-up of contaminants, Reapor can be washed or treated with an anti-fungicide.

HAS IT BEEN INDEPENDENTLY TESTED FOR SOUND ABSORPTION?

Reapor has been independently tested by Fraunhofer Institut Stuttgart, Germany (25 and 50 mm thickness) and CSIRO Melbourne, Australia (50 mm thickness), achieving a noise reduction coefficient (NRC) of 0.95 for 50 mm.

WHAT SIZE PANELS ARE AVAILABLE?

Three standard panel sizes are available:

- 625 x 625 mm (25 or 50 mm thickness)
- 1200 x 625 mm (25 mm thickness)
- 1250 x 625 mm (50 mm thickness)

Notes:

- Lead times may apply for the above sizes
- 625 mm is the maximum and optimum production width. Smaller panels are made by milling-down the width (involves waste).
- A custom thickness up to 65 mm is available
- 25 mm thick Reapor does not have chamfered edges



IS IT EASY TO INSTALL?

Reapor is easily installed using various methods – please refer to the Installation Guide for more information. Reapor panels can be cut with standard woodworking equipment, ensuring the use of woodworking dust protection.

HOW IS IT PACKAGED?

Reapor is packaged in cardboard boxes on pallets. The minimum order quantity for our stock standard size (625 x 625 x 50 mm) is five panels or one pack (five panels per pack). Bulk orders are shipped in 20 ft or 40 ft containers.

IS IT EASILY REPAIRED?

Marks in Reapor panels can be removed using a small piece of Reapor as a sanding block. For holes and punctures, use a clear acrylic binder with some crumbled granules.

IS IT SUITABLE FOR OUTSIDE?

Yes! Reapor resists weather, water and UV exposure over an extended period of time. It is also resistant to chlorides and potassium, and so will survive without further protection in coastal areas. (The product may effloresce, leaving a white colour on the face of the panel – however, this will not affect the performance of the panel.)

WHY DOES REAPOR HAVE BETTER ACOUSTIC QUALITIES THAN SIMILAR GLASS BEAD PANELS?

There are no binders used to enhance absorption performance.

IS IT FIRE-RATED? IF SO TO WHAT STANDARD?

Reapor is non-combustible according to EN 13501-1, DIN 4102, AS 1530.1 / ISO 1182.

CAN IT BE USED ON ROADWAY/TRAFFIC BARRIERS?

Yes – in conjunction with concrete structures, Reapor is ideal for use in road barriers, train tunnels and similar applications.



pyroteknc.com

PYROTEK WORLDWIDE LOCATIONS

AUSTRALIA

CANADA

CHINA

CZECH REPUBLIC

HONG KONG

INDIA

INDONESIA

JAPAN

KOREA

MALAYSIA

SINGAPORE

NEW ZEALAND

TAIWAN

THAILAND

TURKEY

UNITED ARAB EMIRATES

UNITED KINGDOM

UNITED STATES OF AMERICA

VIETNAM

REAPOR® IS A REGISTERED TRADEMARK OF LIAVER USED WITH PERMISSION FOR PYROTEK AS DISTRIBUTORS.

CONTACT DETAILS

For further information please visit our website:
pyroteknc.com

Pyrotek endorse forest sustainability and the preservation of natural environment. We procure the highest quality materials from suppliers who hold FSC (Forest Stewardship Council) Certification and PEFC (Programme for the Endorsement of Forestry Certification) amongst other certification programmes.

Caveats: Specifications are subject to change without notice. The data in this document are typical of average values based on tests by independent laboratories or by the manufacturer and are indicative only. Materials must be tested under intended service conditions to determine their suitability for purpose. The conclusions drawn from acoustic test results are as interpreted by qualified independent testing authorities. Nothing here releases the purchaser/user from responsibility to determine the suitability of the product for their project needs. Always seek the opinion of your acoustic, mechanical or fire engineer on data presented by the manufacturer. Due to the wide variety of individual projects, Pyrotek NC is not responsible for differing outcomes from using their products. Pyrotek disclaims any liability for damages or consequential loss as a result of reliance solely on the information presented. No warranty is made that the use of this information or of the products, processes or equipment to which this Information Page refers will not infringe any third party's patents or rights. DISCLAIMER: This document is covered by Pyrotek standard Disclaimer, Warranty and © Copyright clauses. See pyroteknc.com/disclaimer.

SOUND ABSORBERS



Sorbermel is a flexible, lightweight, open-cell, light grey foam made from melamine resin. It is **highly flame retardant** with **excellent sound absorption** and **thermal insulation** properties.

SORBERMEL®

Sorbermel® features a three-dimensional delicate network structure of slender filaments. Its open-cell structure enhances sound absorption and traps noise energy to prevent it from reflecting as an echo.

Sorbermel® can be easily laminated with many other suitable products to increase acoustic performance in any project. The perfect option for aesthetic challenges it can be used as baffles, acoustic panels, or as infills with other materials to form decorative acoustic composites.

Features

- Wide sound absorption range and thermal insulation properties
- Excellent fire retardant properties
- Lightweight - offers energy efficiency and passenger safety in the transport industry
- Free of mineral fibres and resists hydrolysis
- Long service life - constant physical properties over a wide temperature range

Application

- Wall and ceiling linings and enclosures for industrial plant and equipment rooms
- Enclosures: HVAC, Air conditioners, machinery, equipment, compressor and gen set enclosures
- Any other building applications with stringent fire rating compliance requirements where acoustic or thermal insulation properties are required



Tile size: 2500 X 1300 mm Thickness: 5 mm to 100 mm
Custom sizes available depending on MOQ
Available facings: Sorbermel AGC, Sorbermel GC

Technical Datasheet



SORBERMEL®

fire-resistant and sound-absorbing melamine foam

Sorbermel is a flexible, open-cell, acoustic and thermal insulation product constructed using a melamine insulation base. It is lightweight, flame retardant and offers excellent sound absorption and thermal insulation properties. The product is also available with a variety of facings to enhance its fire-resistant properties or to provide a layer of protection to the melamine base.

Sorbermel is dimensionally stable, inherently moisture resistant and resists foam rot. The foam structure features a 3D network of thin melamine resin filaments that absorbs sound energy to prevent reverberation.

Being low-weight, it contributes to the energy efficiency of rail and utility vehicles, enhancing passenger safety. It's also particularly suited to building interiors where surfaces of insulation are exposed.

Sorbermel is a favoured choice in weight-sensitive applications, harsh environmental conditions, or where enhanced fire safety properties are required. Its unique flexibility allows for easy installation with basic tools, making it perfect for use in rail, marine, automotive, building or construction industry.

VOC, ODP, HEALTH AND SAFETY

Sorbermel is non-toxic and safe to handle by methods prescribed in the Safety Data Sheet.

SPECIFICATIONS

Colour	Light grey
Available	Standard sheet size: 2.5 m x 1.3 m (8.2 ft x 4.3 ft) Thickness range: 5 to 100 mm (0.2 to 3.9 in)
	Custom sizes, facings and/or thicknesses available depending on MOQ

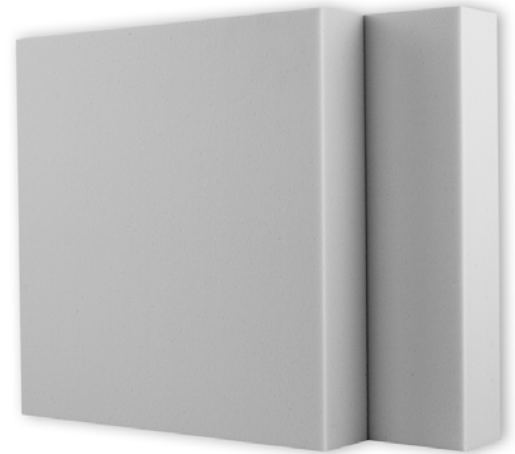

applications

- Transport: engine compartments and cabin insulation for trains, buses, trucks or automotive
- Commercial buildings: HVAC systems
- Industrial: Machinery/generator set enclosures, electrical equipment, wall/ceiling linings for plant and equipment rooms

features

- Lightweight - offers energy efficiency/passenger safety in the transport industry
- Wide sound absorption range and high thermal insulation properties
- Excellent fire retardant properties
- High continuous operating temperature
- Free of mineral fibres
- Resists hydrolysis - will not rot
- Long service life - constant physical properties over a wide temperature range
- Self-supporting – no additional structures required to maintain shape
- Easy to cut, shape, fabricate and install
- Custom kit options available to meet size requirements
Available with different surface coverings and self-adhesive backing for ease of installation
- Available with hydrophobic treatment



PRODUCT SPECIFICATION

Thickness	Density EN ISO 845	Standard sheet size (Length x Width)	Thermal conductivity (W/mK) DIN 12667	Elongation at break DIN 53571	Compressive strength EN ISO 3386-1	Tensile strength ISO 1798	Operating temperature DIN EN ISO 2578
5 to 100 mm (0.2 to 3.9 in)	9 kg/m ³ (0.56 lb/ft ³)	2.5 x 1.3 m (8.2 x 4.3 ft)	0.035 @ 10 °C (50 °F)	10%	9 kPa (min)	120 kPa (min)	1000h > 200 °C (392 °F) 20000h > 150 °C (302 °F) Minimum -50 °C (-58 °F)

Tolerances: Length: -0/+50 mm (2 in); Width: -0/+5 mm (0.2 in); Thickness: ±2 mm (0.08 in); Density: ±1.5 kg/m³ (0.09 lb/ft³)

Results based on BASF Basotect® G+

All above products are available with pressure-sensitive adhesive backing. Under extreme temperature and humidity conditions, air flow or where the substrate surfaces cannot be free from contaminants, mechanical fixing will be required. For all inverted installations including ceiling installations, mechanical fixing must be done in addition to pressure sensitive adhesive. Please consult your local Pyrotek representative for more information.

MATERIAL PROPERTIES

Test method	Property	Report no.	Results
EN 45545-2 (ISO 5658-2)	Spread of flame	0168-23-F	R1 , R7 (HL1, HL2, HL3)
EN45545-2 (EN 17084 (1) : 50 kWm ⁻²)	Gas Toxicity		
EN 45545-2 (ISO 5660-1: 50kWm ⁻²)	Heat release rate by cone calorimeter		
EN 45545-2 (ISO 5659-2: 50kWm ⁻²)	Smoke generation (optical density)		
AS 5637.1/NZS 3837:1998	Fire hazard properties	FH 4999	Group 1
UL94	Flammability of plastic materials	13513JY3	HF-1 Self-extinguishing (SE)
FMVSS 302	Flammability of interior materials	14713JY4	Complies to the requirements of US (DOT) Department of transport for occupant
ASTM E 162	Surface Flammability	105447856MID-001	Complies for US (FRA) Federal railroad administration requirements and requirements of NFPA 130 - Complies for US (DOT) Department of transportation requirements for acoustic insulation of transit bus and vans (Docket 90A)
ASTM E 662	Optical Density of Smoke Generated	105447856MID-002REV1	
BOMBARDIER SMP 800C	Toxic gas generation	105447856MID-003	

ACOUSTIC PERFORMANCE

Frequency (Hz)	Sorbermel 25 mm	Sorbermel 50 mm
100	0.06	0.13
125	0.10	0.16
160	0.11	0.23
200	0.15	0.31
250	0.21	0.54
315	0.25	0.69
400	0.37	0.83
500	0.49	0.97
630	0.60	0.95
800	0.69	0.94
1000	0.79	0.97
1250	0.81	0.96
1600	0.82	0.90
2000	0.83	0.87
2500	0.83	0.91
3150	0.87	0.93
4000	0.88	0.93
5000	0.86	0.91
NRC	0.60	0.85
SAA	0.57	0.82
α_w	0.50 (MH)	0.80

Tested to ISO 354:2003 at University of Canterbury, New Zealand
Report Numbers: 297 & 298

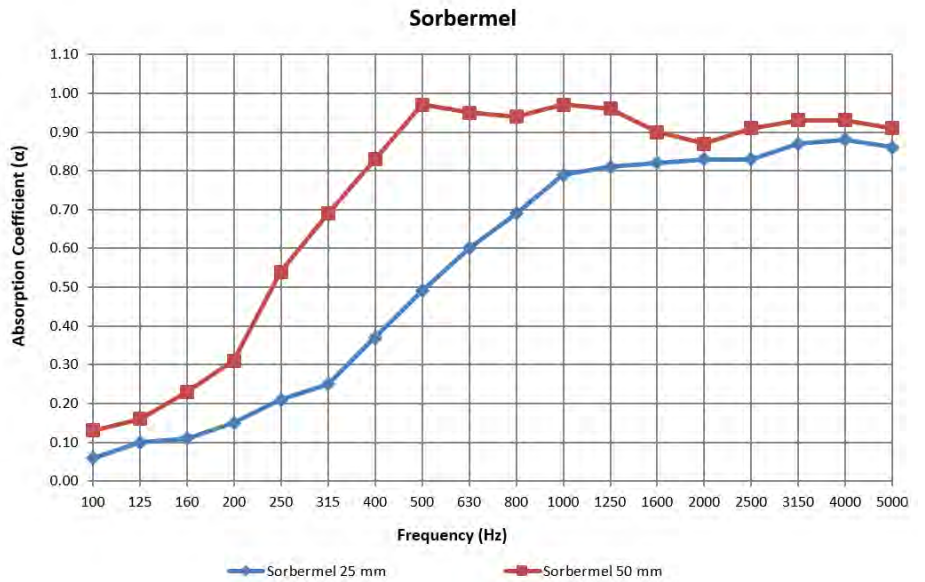

For further information and contact details, please visit our website pyroteknc.com

Caveats: Specifications are subject to change without notice. The data in this document is typical of average values based on tests by independent laboratories or by the manufacturer and are indicative only. Materials must be tested under intended service conditions to determine their suitability for purpose. The conclusions drawn from acoustic test results are as interpreted by qualified independent testing authorities. Nothing here releases the purchaser/user from responsibility to determine the suitability of the product for their project needs. Always seek the opinion of your acoustic, mechanical and fire engineer on data presented by the manufacturer. Due to the wide variety of individual projects, Pyrotek is not responsible for differing outcomes from using their products. Pyrotek disclaims any liability for damages or consequential loss as a result of reliance solely on the information presented. No warranty is made that the use of this information or of the products, processes or equipment to which this Information Page refers will not infringe any third party's patents or rights. DISCLAIMER: This document is covered by Pyrotek standard Disclaimer, Warranty and © Copyright clauses. See pyroteknc.com/disclaimer.



SORBERMEL® GC

fire retardant and sound absorbing melamine foam with a glass cloth surface facing

Sorbermel GC is a flexible, open-cell, acoustic and thermal insulation product constructed using a melamine insulation base, thermally bonded with a fire-rated glass cloth (GC) facing. It is lightweight, flame retardant and offers excellent sound absorption and thermal insulation properties.

The GC facing is bonded to the insulation base, using micro-perforated webbing. The inherent properties of the GC face complement the fire and thermal insulation performance of the product. It also protects the melamine base from damage and prevents dirt ingress.

Sorbermel foam is dimensionally stable, inherently moisture resistant and resists foam rot. The foam structure features a 3D network of thin melamine resin filaments that absorbs sound energy to prevent reverberation.

Being low-weight, it contributes to the energy efficiency of rail and utility vehicles, enhancing passenger safety. It's also particularly suited to building interiors where surfaces of insulation are exposed.

Sorbermel GC is a favoured choice in weight-sensitive applications, harsh environmental conditions or where enhanced fire safety properties are required. Its unique flexibility allows for easy installation with basic tools, making it perfect for use in rail, marine, automotive, building or construction industry.

SPECIFICATIONS

Colour	Grey and black (additional colours available on request depending on MOQ)
Available	Standard sheet: 1.2 x 2.4 m trimmed Thickness: 25 or 50 mm (Available thickness 10 to 100 mm)
	Custom sizes and custom kit options available depending on MOQ



applications

- Transport: engine compartments and cabin insulation for trains, buses, trucks or automotive
- Commercial buildings: HVAC systems
- Industrial: Machinery/generator set enclosures, electrical equipment, wall/ceiling linings for plant and equipment rooms
- Boats and marine survey

features

- Lightweight - offers energy efficiency/passenger safety in the transport industry
- Wide sound absorption range and high thermal insulation properties
- Excellent fire retardant properties
- High continuous operating temperature
- Free of mineral fibres
- Resists hydrolysis - will not rot
- Long service life - constant physical properties over a wide temperature range
- Self-supporting – no additional structures required to maintain shape
- Easy to cut, shape, fabricate and install
- Custom kit options available to meet size requirements
- Available with different surface coverings and self-adhesive backing for ease of installation
- Available with hydrophobic treatment



PRODUCT SPECIFICATIONS

Product	Standard thickness	Density (foam)	Sheet size	Thermal conductivity (DIN 52612)	Elongation at break (DIN 53571)	Tensile strength (DIN 53571)	Operating Temperature range
Sorbermel GC 25	25 mm (0.98 in)	9 kg/m ³ (0.56 lb/ft ³)	1.2 x 2.4 m (3.9 ft x 7.9 ft) trimmed	0.035 W/mK	10%	120 kPa (min)	-40 to 150 °C (-40 to 302 °F)
Sorbermel GC 50	50 mm (1.97 in)						

Tolerances: Length: -0, +50 mm (2 in); Width: -0, +5 mm (0.2 in); Thickness: ± 2 mm (0.08 in); Density: Density: ±1.5 kg/m³ (0.09 lb/ft)

All above products are available with pressure-sensitive adhesive backing. Under extreme temperature and humidity conditions, air flow or where the substrate surfaces cannot be freed from contaminants, mechanical fixing will be required. For all inverted installations including ceiling installations, mechanical fixing must be done in addition to pressure sensitive adhesive. Please consult your local Pyrotek representative for more information.

MATERIAL PROPERTIES

Test method	Property	Report	Results
AS/NZS 3837	Fire hazard properties	FH 4999	Group 1*
UL94	Flammability of plastic materials	15014BD	Self-extinguishing (SE)
FMVSS-302	Flammability of interior materials	15014BD1	Complies to the requirements of US (DOT) Department of transportation for occupant compartments of motor vehicles

*Results apply to unfaced melamine foam

ACOUSTIC PERFORMANCE

Frequency (Hz)	Sorbermel GC 25 mm	Sorbermel GC 50 mm
100	0.02	0.13
125	0.05	0.20
160	0.09	0.28
200	0.20	0.50
250	0.33	0.86
315	0.47	1.11
400	0.70	1.17
500	0.87	1.18
630	0.95	1.09
800	1.03	1.09
1000	1.06	1.07
1250	1.04	1.00
1600	1.00	1.00
2000	1.00	0.92
2500	0.98	0.88
3150	0.96	0.89
4000	0.91	0.92
5000	0.83	0.86
NRC	0.80	1.00
SAA	0.80	0.99
α_w	0.65 (MH)	1.00

Tested to ISO 354:2003 at University of Canterbury, New Zealand
Report Numbers: 301 & 302

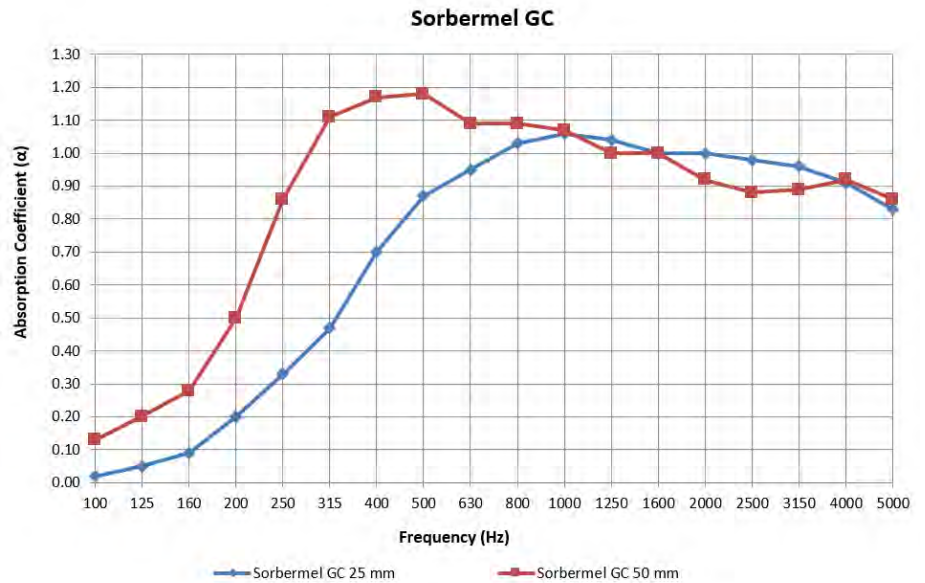

For further information and contact details, please visit our website pyroteknc.com

Caveats: Specifications are subject to change without notice. The data in this document is typical of average values based on tests by independent laboratories or by the manufacturer and are indicative only. Materials must be tested under intended service conditions to determine their suitability for purpose. The conclusions drawn from acoustic test results are as interpreted by qualified independent testing authorities. Nothing here releases the purchaser/user from responsibility to determine the suitability of the product for their project needs. Always seek the opinion of your acoustic, mechanical and fire engineer on data presented by the manufacturer. Due to the wide variety of individual projects, Pyrotek is not responsible for differing outcomes from using their products. Pyrotek disclaims any liability for damages or consequential loss as a result of reliance solely on the information presented. No warranty is made that the use of this information or of the products, processes or equipment to which this Information Page refers will not infringe any third party's patents or rights. **DISCLAIMER:** This document is covered by Pyrotek standard Disclaimer, Warranty and © Copyright clauses. See pyroteknc.com/disclaimer.



NOISE BARRIERS

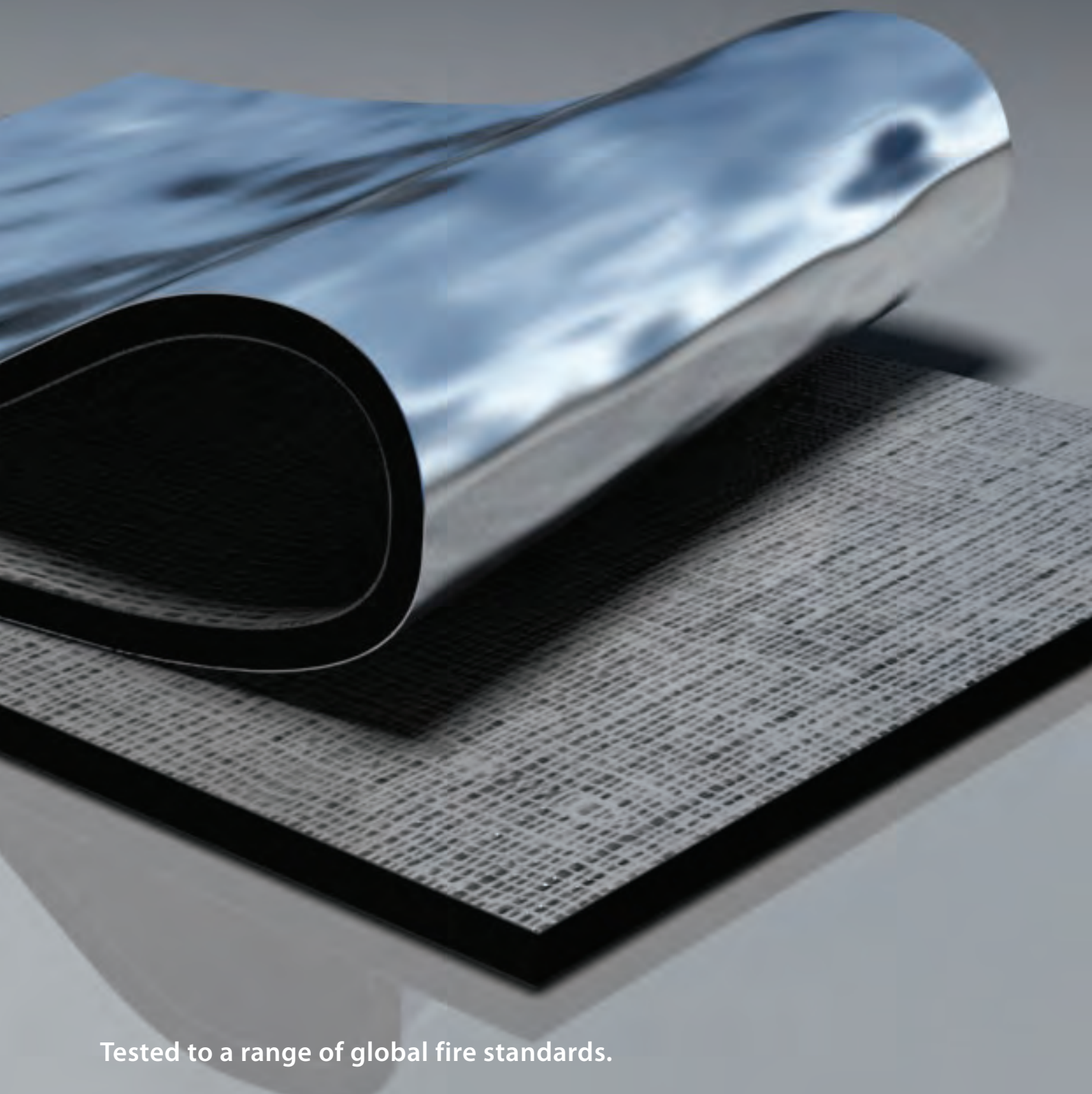

Tested to a range of global fire standards.

Quadzero™ and Quadzero™ NL are a foil faced mass-loaded vinyl noise barrier offering superior acoustic transmission loss and low spread of flame surface covering. It performs similarly to Wavebar® but with the added fire-resistant facing.

QUADZERO™

Quadzero™ is a flame resistant foil faced MLV offering superior acoustic transmission loss with high flame retardant properties. The reflective foil facing provides a low spread of flame surface covering for areas where higher fire specifications are required. Additionally, the dense, thin and strong physical characteristics make Quadzero suitable for building, industrial, transport and OEM sectors. It is also highly suitable for Liquid Natural Gas (LNG) pipe application.

Features

- Complies to AS1530.3 & BS 467.6/7 building codes
- Tear resistant with high tensile strength - ability to be suspended at lengths of up to 5 metres
- Available with various laminates such as foams, polyesters and fibreglass



Wavebar® 4 kg/m ²	Wavebar® 6 kg/m ²
Rw 25	Rw 28
Wavebar® 8 kg/m ²	Wavebar® 10 kg/m ²
Rw 31	Rw 34

Standard roll size: Width: 1380 mm Length: 5 to 10 m
Custom sizes available depending on MOQ

QUADZERO™ NL

Quadzero™ NL is a foil faced barrier that is formulated to achieve the highest fire rating as an acoustic surface covering. It is durable, flexible and tear resistant, with a strong base fabric. This product offers optimum noise transmission loss with fire testing results that complies with international marine and rail standards. Quadzero NL is suitable for marine and rail carriages in walls, ceilings and under floor insulation, as it contains no ozone depleting substances, lead, unrefined oils or bitumen.

Features

- Tested to ASTM E84 achieving Class A (interior finishes), International Building Code
- Tear resistant with high tensile strength - ability to be suspended at lengths of up to 5 metres

Application

Quadzero™ and Quadzero™ NL is ideally installed similar to Wavebar® (inside cavities, over lightweight wall/ceilings, between the plenum chamber of a floor slab, the roof and adjoining partition walls) to meet building code fire requirements.



Wavebar® 4 kg/m ²	Wavebar® 6 kg/m ²
Rw 25	Rw 28
Wavebar® 8 kg/m ²	Wavebar® 10 kg/m ²
Rw 31	Rw 34

Technical Datasheet



QUADZERO™

foil faced flexible noise barrier

Quadzero™ is a high-performance, foil faced, mass-loaded vinyl noise barrier, offering superior acoustic transmission loss and low spread of flame surface covering.

Quadzero™ was developed to meet market noise reduction requirements in the domestic, commercial, industrial and OEM sectors.

To achieve this high-performance, the Pyrotek® engineering team developed Quadzero™ to be dense, thin, strong, tear-resistant and highly flexible. These properties give the product high transmission loss throughout the various weight ranges. It complies with British and international fire and building codes for low spread of flame.

Stiff lightweight panel constructions, such as plasterboard, drywall, plywood and hollow core walls, typically have coincidence dip resonance which allows noise to transmit through a construction. The coincidence dip is dependent on the material's stiffness and thickness and occurs at the point where the sound transmitted through the structure matches the natural frequency of the panel.

Quadzero™ shifts the coincidence dip to frequencies limiting its impact, thereby maintaining the performance of the product. The thin, dense mass Quadzero™ barrier reflects and absorbs the transmission of sound through walls, ceilings and floors, reducing the critical frequencies generated from mechanical equipment, engine noise and electronic audio devices.

VOC STATEMENT

No Ozone depleting substances are used during the manufacture of Quadzero™. No Volatile Organic Compounds (VOC) are intentionally added to Quadzero™ during its manufacture. Quadzero™ is not considered to sustain vermin or have susceptibility to damage from vermin.

SPECIFICATIONS

Colour	Silver (Aluminium face)
Available	Width: 1350 mm
	Length (linear m): 5 - 10 m
	Weight (kg/m ²): 2, 4, 6, 8, 10
	Custom depending on MOQ



applications

- Inside cavities or over lightweight wall, ceiling and floor constructions. Ideal for home theatres, office partitions, meeting rooms.
- Over roof joists to reduce aircraft, rail and traffic noise.
- Applied between the plenum chamber of a floor slab, roof and adjoining partition walls.
- Installed around the outside of metal air ducts to reduce noise break-out.
- Wrapped around noisy pipes, valves and fan casings e.g. fluid or gas pulsation in chemical, petrochemical, wastewater treatment plants and oil & gas pipelines.
- Automotive firewalls to reduce engine and road noise transmitting through the structure.
- Rail carriages for under floor insulation to reduce track and braking noise.

features

- Complies to AS1530.3 building code requirements
- Free from lead, odour-producing oils and bitumen
- Can be fitted around challenging places
- The foil facing also makes it easy to bond onto other substrates using matching Tape ALR adhesive or equivalent.
- Simple to cut, sew, tape and mechanically fasten
- Resistant to water, oil and natural weather conditions
- Tear resistant with high tensile strength. Ability to be suspended in lengths of up to 5 metres
- Available with various laminates such as foams, polyesters and fibreglass



PRODUCT SPECIFICATIONS

Barrier weight (kg/m ²)	Thickness (mm)	'k' value (W m ⁻¹ K ⁻¹)	Roll			Ceiling Sound Transmission Test AMA-1-II-1967 (CSTC)	Operating temp. range (°C)
			Width (mm)	Length (linear m)	Weight (kg)		
2	1.2	0.49 (Report No. 09/1182)	1350	10	27	44 (Report No. A-22104-0228)	-40 to 100 (Continuous) -40 to 120 (Intermittent)
4	2.0			5 or 10	27 - 54	48 (Report No. -22107-0228)	
6	3.0			5	41	-	
8	4.0			5	54	50 (Report No. 22114-0228)	
10	4.9			5	68	-	

Tolerances: Length: -0/+50mm; Width: -0/+5mm; Thickness: +/- 0.5mm; Weight: +/- 10%

MATERIAL PROPERTIES

Test method	Property	Report no.	Results
AS 1530.3	Ignitability, flame propagation, heat and smoke release	20-005160	0,0,0-1
AS 3837 / ISO 5660-1	Fire hazard properties	FH18406-01-1	Group 3*
BS 6853 Annex B2	Weighted summation of toxic fume	2974/R1	R 0.050
BS 6853 Annex D 8.6	Smoke density	377170	Cat 1b
BS476 part 7	Surface spread of flame	431606	Class 1
FMVSS-302	Flammability of interior materials	02313BD8	Complies to the requirements of US (DOT) Department of transportation for occupant compartments of motor vehicles

*Quadzero Black - Black foil facing

ACOUSTIC PERFORMANCE

Frequency (Hz)	2 kg/m ²	4 kg/m ²	6 kg/m ²	8 kg/m ²	10 kg/m ²
100	3.8	6.7	11.6	13.3	18.9
125	6.4	10.8	13.8	16.2	19.3
160	10.2	14.7	17.3	22.6	22.6
200	9.8	14.1	17.2	20.5	23.4
250	12.0	16.0	18.7	22.3	25.2
315	13.2	17.9	20.4	23.2	26.1
400	14.8	19.7	22.7	25.0	28.1
500	15.8	20.6	24.1	26.0	29.3
630	17.8	22.6	26.1	28.6	30.5
800	20.0	25.0	27.7	30.1	32.3
1000	21.7	26.6	30.2	32.7	34.9
1250	22.7	27.6	30.3	33.4	35.7
1600	23.9	28.5	31.2	34.1	36.4
2000	25.6	30.4	33.6	35.9	38.4
2500	27.7	32.1	35.4	37.6	40.4
3150	29.9	34.3	37.7	39.7	42.7
4000	32.2	36.7	40.6	42.1	45.7
5000	34.6	39.0	43.3	45.0	48.7
Rw	21	25	28	31	34
STC	21	26	28	31	34

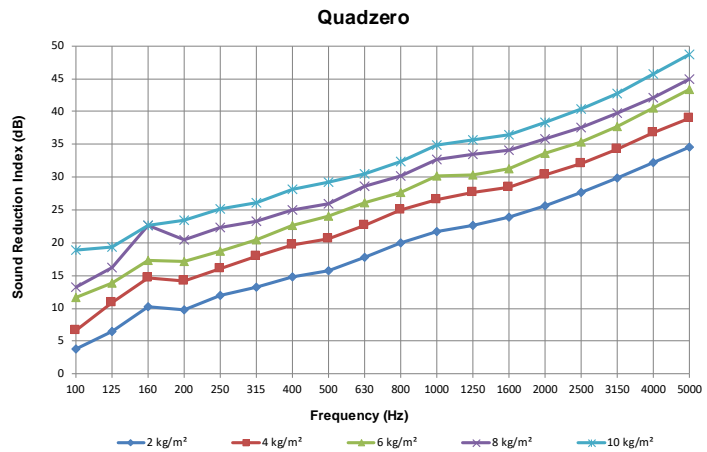

ISO 15665 PIPE INSULATION TESTING

Barrier Weight	Test method	System Assembly	Report no.	Results
6 kg/m ²	ISO 15665 (Group 2 Pipe Size)	Available on request	A 3041-1E-RA-002	ISO 15665: Class A2 & B2 NORSOK R-004: Class 6 & Class 7
6 kg/m ² & 10 kg/m ²	ISO 15665 (Group 2 Pipe Size)	Available on request	A 3041-4E-RA-002	ISO 15665: Class B2 & C2 NORSOK R-004: Class 7 & Class 8

Tested to ISO 15186-1:2003 & 10140-4:2010 at University of Canterbury, New Zealand
Report Number: 261c, 262c, 263c, 264c & 265c

Testing was conducted using Wavebar®

For further information and contact details, please visit our website pyroteknc.com

Caveats: Specifications are subject to change without notice. The data in this document is typical of average values based on tests by independent laboratories or by the manufacturer and are indicative only. Materials must be tested under intended service conditions to determine their suitability for purpose. The conclusions drawn from acoustic test results are as interpreted by qualified independent testing authorities. Nothing here releases the purchaser/user from responsibility to determine the suitability of the product for their project needs. Always seek the opinion of your acoustic or mechanical engineer on data presented by the manufacturer. Due to the wide variety of individual projects, Pyrotek is not responsible for differing outcomes from using their products. Pyrotek disclaims any liability for damages or consequential loss as a result of reliance solely on the information presented. No warranty is made that the use of this information or of the products, processes or equipment to which this Information Page refers will not infringe any third party's patents or rights. **DISCLAIMER:** This document is covered by Pyrotek standard Disclaimer, Warranty and © Copyright clauses. See pyroteknc.com/disclaimer.



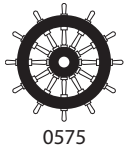

QUADZERO™ NL

fire-resistant, foil faced flexible noise barrier

Quadzero™ NL is a high-performance foil faced mass-loaded vinyl noise barrier, offering superior acoustic transmission loss and upgraded fire resistance.

With a fire-resistant foil facing, Quadzero™ NL was developed by Pyrotek® to meet stringent fire safety requirements in the marine, building and transport sectors. The product achieves the highest fire ratings complying with International Marine Organisation standards for low spread of flame, as well as international building and transportation standards for heat release, toxicity and flame propagation properties.

The upgraded fire safety provided by Quadzero™ NL is offered without reducing the strength, tear resistance or flexibility offered by the Wavebar® Quadzero™ product range.

Stiff lightweight panel constructions, such as plasterboard, drywall, plywood and hollow core doors, typically have coincidence dip resonance which allows noise to transmit through a construction. The coincidence dip is dependent on the material's stiffness and thickness and occurs at the point where the sound transmitted through the structure matches the natural frequency of the panel. Quadzero™ NL shifts the coincidence dip to frequencies limiting its impact, thereby maintaining the performance of the product.

The thin, dense mass barrier reflects and absorbs the energy, resulting in the reduction of transmission of sound through walls, ceilings and floors, therefore reducing the noise generated from sources such as mechanical equipment, engine noise and electronic devices.

VOC STATEMENT

Quadzero™ products contain no ozone-depleting substances and comply with European and Australian standards for Volatile Organic Compound emissions.

SPECIFICATIONS

Colour	Silver (Aluminium facing) White backing
Available	Width: 1350 mm Length (m): 5 to 10 m Weight (kg/m ²): 2, 4, 6, 8, 10
	Custom sizes available depending on MOQ

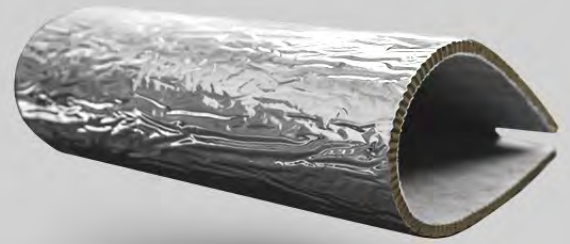

applications

- Applied in marine engine rooms & deckheads to reduce noise transmission
- Rail carriages for under floor insulation to reduce track and brake noise
- Inside cavities or over lightweight wall, ceiling and floor constructions
- Around the outside of metal air ducts to reduce noise breakout
- Wrapped around noise emitting pipes, i.e. fluid or gas pulsation in chemical, petrochemical and waste water treatment plants

features

- Complies to IMO FTP 2010 - low spread of flame
- Multiple methods of installation accepted by USA Coast Guard (USCG)
- Complies to BS 476 Part 6 and 7 - Class 0
- Contains no ozone depleting substances
- Free from lead, unrefined odour-producing oils and bitumen
- Easy to cut, tape and mechanically fasten into position
- Self-extinguishes upon removal of flame
- Resistant to water, oil and natural weather conditions
- Tear resistant with high tensile strength - ability to be suspended at lengths of up to 5 metres



PRODUCT SPECIFICATIONS

Barrier weight (kg/m ²)	Thickness (mm)	Thermal conductivity k value (Wm ⁻¹ K ⁻¹)	Roll			Ceiling Sound Transmission Test AMA-1-II-1967 (CSTC)	Operating temp. range (°C)
			Width (mm)	Length (m)	Weight (kg)		
2	1.2	0.49 (Report no. 09/1182)	1350	10	27	44 (Report No. A-22104-0228)	-40 to 100 (Continuous) -40 to 120 (Intermittent)
4	2.0			5 or 10	27 or 54	48 (Report No. A-22107-0228)	
6	3.0			5	41	-	
8	4.0			5	54	50 (Report No. A-22114-0228)	
10	4.9			5	68	-	

Tolerances: Length: ±1%, Width: -0/+5 mm, Thickness: ±0.5 mm, Weight: ±10%

MATERIAL PROPERTIES

Test method	Property	Report no.	Results
IMO FTP Annex 1 Part 5	Surface flammability	377172	Complies for bulkheads, walls or ceiling linings and floors for 2 kg/m ² to 8 kg/m ² products USCG Type approval granted
IMO FTP Annex 2	Smoke and toxicity	377172	
MED B	EC Type Certificate (Module B) for Marine Equipment Directive	MEDB0000750	
MED D	EC Type Certificate (Module D) for Marine Equipment Directive	MEDD000028J	
BS 476 Part 6	Fire propagation	377173, 377176	Complies with Class 0 for 6 kg/m ² to 10 kg/m ²
BS 476 Part 7	Surface spread of flame	377175, 377178	
ISO 1716	Heat of Combustion	348394	5311.6 KJ/Kg
GB8624 (EN 13501)	Fire classification of construction products and building materials	GN201312974	Class B (s2, d0, t0)
GB/T 20284 (EN 13823)	SBI - Single burning item test for building materials and products		
GB/T 8626 (ISO 11925-2)	Ignitability of building materials with direct flame impingement		
GB/T 20285	Toxic classification of fire effluents hazard for materials		
ASTM E84	Surface Burning Characteristics of Building Materials	01.17786.01.063a	Class A (Interior finishes), International Building Code
CAN/ULC S102.2	Test for surface burning characteristics	104572841COQ-001B	FSI: 0, SDI: 15
GB/T 2406.1 & GB/T 2406.2	Burning behaviour by oxygen index	SZML110704163	31.5%
TB/T 3138	Specification of flame retardant materials for railway vehicle	SZML110704163	Complies
FMVSS 302	Flammability of interior materials	02313BD2	Complies to the requirements of US (DOT) Department of Transport for occupant compartments of motor vehicles
EN 45545-2 (ISO 5658-2)	Spread of flame	0106-23-F	R1, R7 HL3 Complies for 2 kg/m ² to 8 kg/m ² products
EN 45545-2 (ISO 5660-1: 50 kWm ⁻²)	Heat release rate by cone calorimeter		
EN 45545-2 (ISO 5659-2: 50 kWm ⁻²)	Smoke generation (optical density)		
EN 45545 -2 (EN 17084 (1): 50 kWm ⁻²)	Gas Toxicity		

ACOUSTIC PERFORMANCE

Frequency (Hz)	2 kg/m ² (dB)	4 kg/m ² (dB)	6 kg/m ² (dB)	8 kg/m ² (dB)	10 kg/m ² (dB)
100	3.8	6.7	11.6	13.3	18.9
125	6.4	10.8	13.8	16.2	19.3
160	10.2	14.7	17.3	22.6	22.6
200	9.8	14.1	17.2	20.5	23.4
250	12.0	16.0	18.7	22.3	25.2
315	13.2	17.9	20.4	23.2	26.1
400	14.8	19.7	22.7	25.0	28.1
500	15.8	20.6	24.1	26.0	29.3
630	17.8	22.6	26.1	28.6	30.5
800	20.0	25.0	27.7	30.1	32.3
1000	21.7	26.6	30.2	32.7	34.9
1250	22.7	27.6	30.3	33.4	35.7
1600	23.9	28.5	31.2	34.1	36.4
2000	25.6	30.4	33.6	35.9	38.4
2500	27.7	32.1	35.4	37.6	40.4
3150	29.9	34.3	37.7	39.7	42.7
4000	32.2	36.7	40.6	42.1	45.7
5000	34.6	39.0	43.3	45.0	48.7
Rw	21	25	28	31	34
STC	21	26	28	31	34

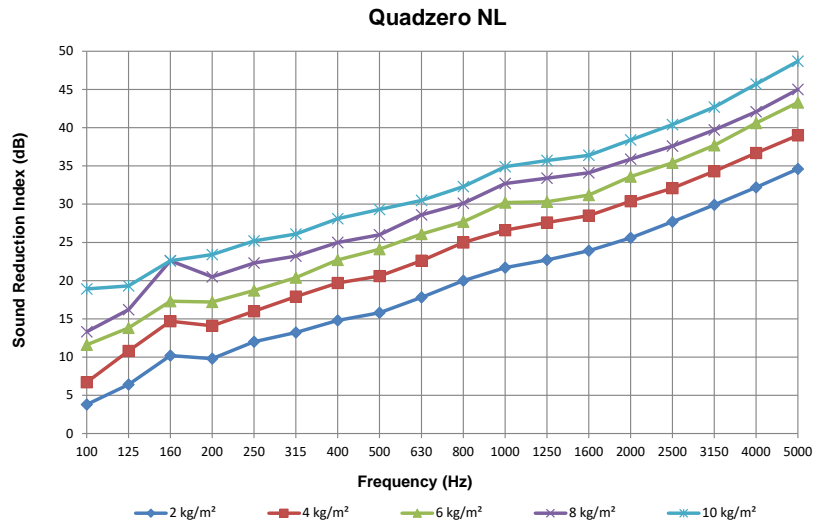

Tested to ISO 15186-1:2003 & 10140-4:2010 at University of Canterbury, New Zealand
Report Numbers: 261d, 262d, 263d, 264d & 265d

ISO 15665 PIPE INSULATION TESTING

Barrier Weight	Test method	System Assembly	Report no.	Results
6 kg/m ²	ISO 15665 (Group 2 Pipe Size)	Available on request	A 3041-1E-RA-002	ISO 15665: Class A2 & B2 NORSOK R-004: Class 6 & Class 7
6 kg/m ² & 10 kg/m ²	ISO 15665 (Group 2 Pipe Size)	Available on request	A 3041-4E-RA-002	ISO 15665: Class B2 & C2 NORSOK R-004: Class 7 & Class 8

Testing was conducted using a system incorporating Wavebar®

For further information and contact details, please visit our website pyroteknc.com

Caveats: Specifications are subject to change without notice. The data in this document is typical of average values based on tests by independent laboratories or by the manufacturer and are indicative only. Materials must be tested under intended service conditions to determine their suitability for purpose. The conclusions drawn from acoustic test results are as interpreted by qualified independent testing authorities. Nothing here releases the purchaser/user from responsibility to determine the suitability of the product for their project needs. Always seek the opinion of your acoustic, mechanical and fire engineer on data presented by the manufacturer. Due to the wide variety of individual projects, Pyrotek is not responsible for differing outcomes from using their products. Pyrotek disclaims any liability for damages or consequential loss as a result of reliance solely on the information presented. No warranty is made that the use of this information or of the products, processes or equipment to which this Information Page refers will not infringe any third party's patents or rights. DISCLAIMER: This document is covered by Pyrotek standard Disclaimer, Warranty and © Copyright clauses. See pyroteknc.com/disclaimer.



Installation Guide



WAVEBAR® | QUADZERO™

This Installation Guide provides recommendations for the application of the Wavebar® and Quadzero™ range to reduce crosstalk ceiling noise.

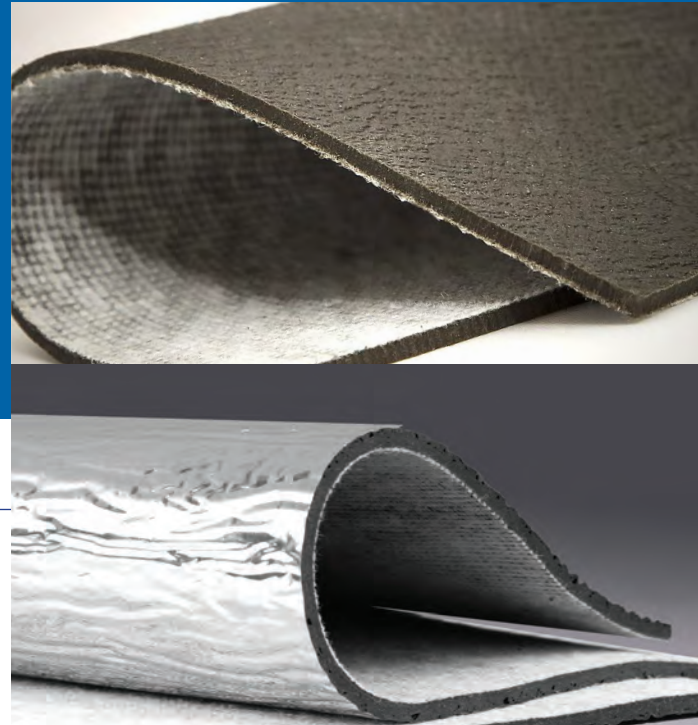

WORKING HEALTH AND SAFETY

- Personal Protection Equipment (PPE), including eye protection, gloves and safety clothing is recommended.

Note: This product is suitable for professional and experienced users only.

DESCRIPTION

Wavebar® and Quadzero™ range barriers are dense, flexible curtains that reflect noise. They are:

- more flexible, practical and economical than full height partitions
- improves confidentiality by virtually eliminating noise from adjacent rooms
- provides cross talk privacy and peace of mind in director's offices, board rooms
- consultation rooms, computer rooms, hallways, nurseries, etc.
- easy to install - ideal for refurbishments. Simply suspend from slab to ceiling tiles, no additional framework is necessary.
- proven project history - wavebar has been utilised in office fitouts and refurbishments for more than three decades as a safe and reliable way to reduce room-to-room noise transmitted via a common ceiling.

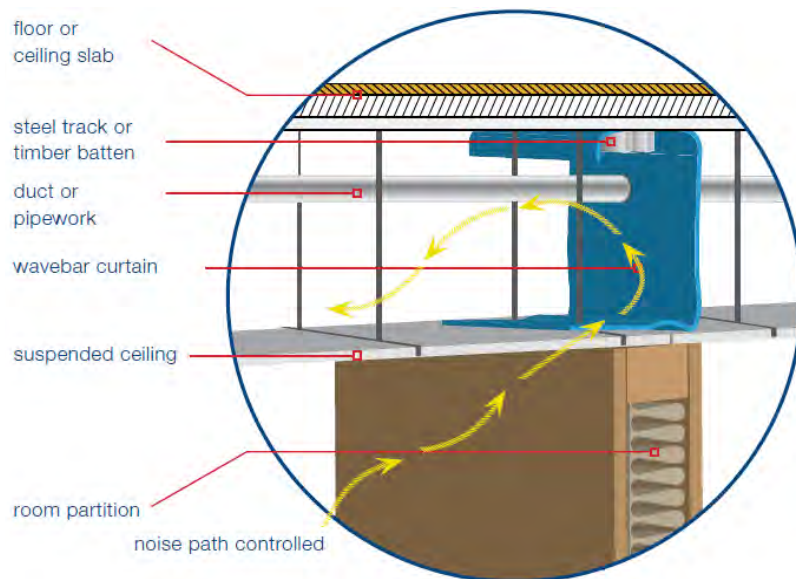

Pyrotek's Wavebar® and Quadzero™ range reduces crosstalk ceiling noise dramatically.

applications

- Inside cavities or over lightweight wall, ceiling and floor constructions. Ideal for home theatre rooms, office partitions, meeting rooms
- Between the plenum chamber of a floor slab, the roof and adjoining partition walls
- Can be laminated onto lightweight structures to damp vibration and reduce airborne noise
- Portable acoustic curtains and screens

Please refer to our website pyroteknc.com for latest information



INSTALLING WAVEBAR/QUADZERO CROSSTALK

- 1. Installation to slab**
Fix metal track or batten and wavebar to slab by mechanical means (masonry nails). Silicone/mastic is recommended to ensure an acoustic seal between Wavebar and slab
- 2. Installation to ceiling**
Allow the noise barrier to drape down onto ceiling on both sides of the ceiling grid. Cut around ceiling suspension hangers
- 3. Installation around pipework or ducting**

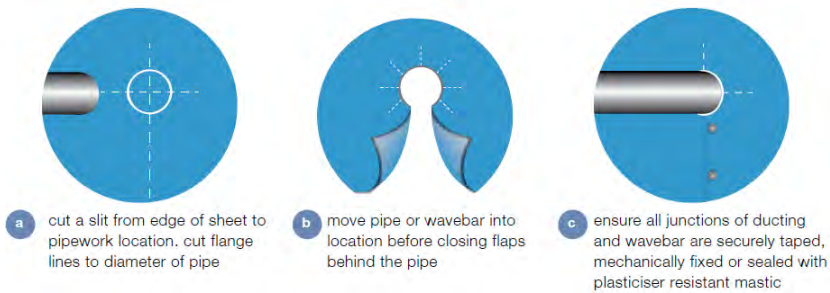

- 4. Installation joins**
Joins for Wavebar® should be overlapped by a minimum of 50 mm and firmly secured by screws/rivets every 100 mm or join with plasticiser resistant mastic.
Quadzero™ range only requires Tape ALR or tape equivalent for joins.
(Please contact your local Pyrotek representative for more information).
- 5. Return air plenums (suggested treatments only)**
Where medium to low acoustic ratings are required return air flow can be channelled through spacing left in baffle above doorways. Where high acoustic ratings are specified, acoustic ducting should be used.

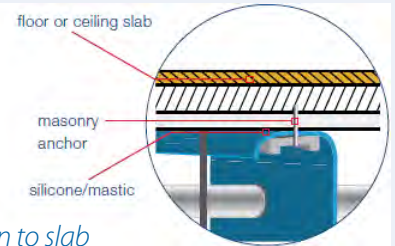

Installation to slab

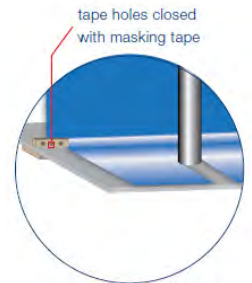

Installation to ceiling

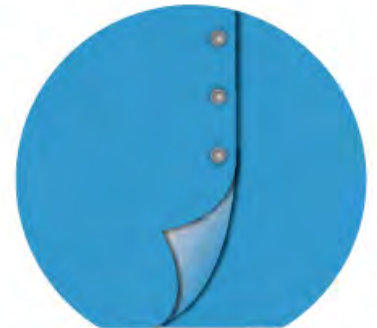

Installation joins

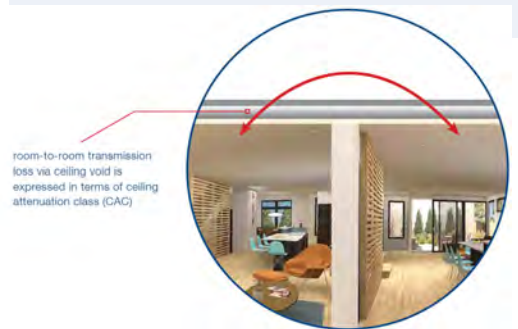
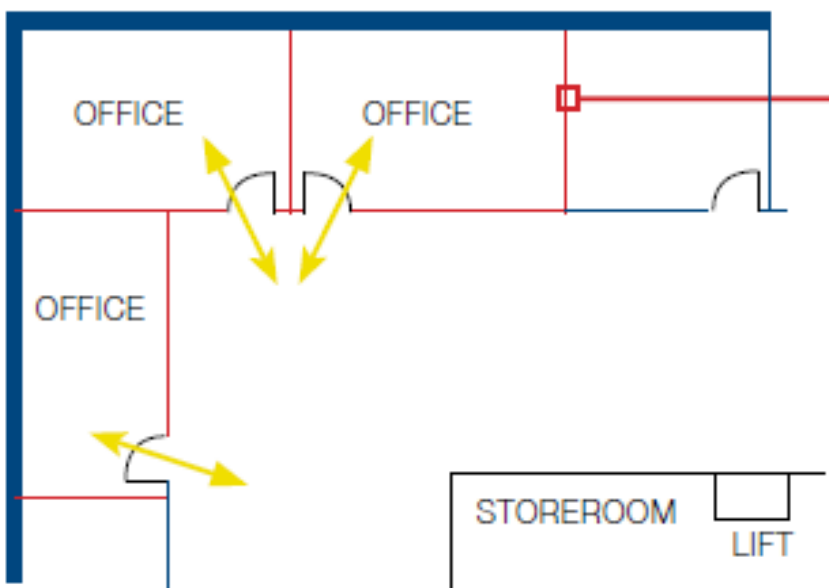

Return air plenums

room-to-room transmission loss via ceiling void is expressed in terms of ceiling attenuation class (CAC)



ACOUSTIC DATA

The following figures represent the tested room-to-room transmission loss achievable when wavebar is utilised in the ceiling plenum between the partition/ceiling and the slab.

- No Wavebar - CAC = 35
- Wavebar 2 kg - CAC = 44
- Wavebar 4 kg - CAC = 48
- Wavebar 8 kg - CAC = 50

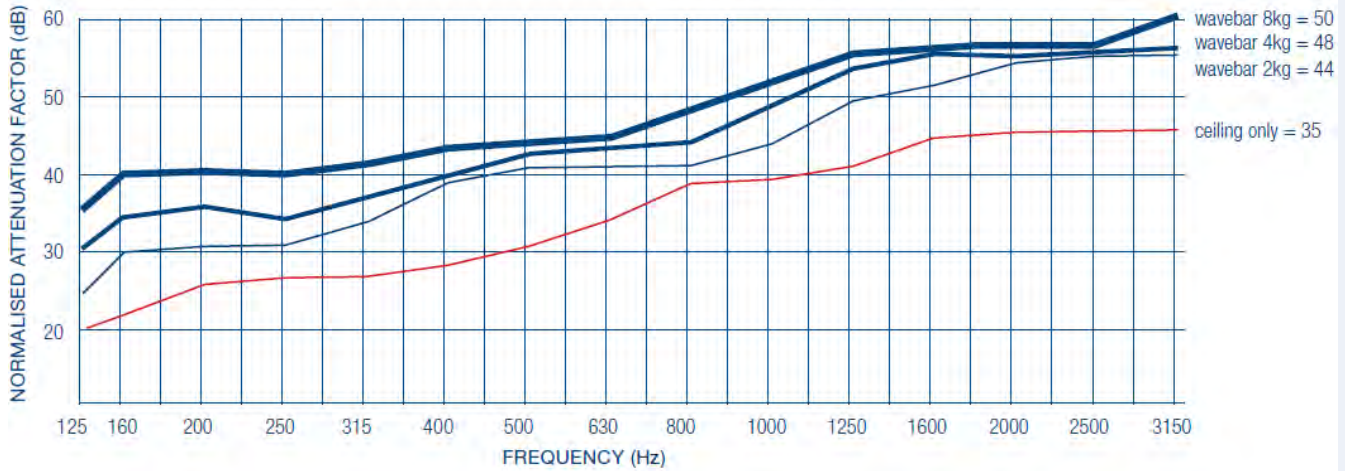

The above figures have been documented as a result of a testing program completed at an accredited laboratory.

Product	Roll width	Roll length	Roll diameter	Weight
wavebar 2kg/m ²	1380mm	10m	200mm	28kg
wavebar 4kg/m ²		5 or 10m		28 - 56kg
wavebar 8kg/m ²		5m		52kg

SPECIFICATIONS

Material

The acoustic sound barrier shall be wavebar mineral loaded PVC as supplied by Pyrotek, comprising barium powder spread evenly throughout and encapsulated with a flexible PVC sheet supported by a polyester fabric. The density shall be a minimum of 1.8g/cm³.

Performance

The Wavebar® barrier shall be 2 kg to achieve 44 CAC, 4 kg to achieve 48 CAC, 8 kg to achieve 50 CAC as documented by full test reports from an accredited laboratory.

Installation

The Wavebar® barrier shall be installed in strict accordance with the manufacturer's recommended procedures as detailed in this wavebar brochure. Care must be taken to seal around pipe or duct penetrations to eliminate sound leakage.

Please contact Pyrotek® for further information or detailed advice on your specific application.

Brochure



FLEXIBLE ACOUSTIC NOISE BARRIER

WAVEBAR AND QUADZERO RANGE



BUILDING - INDUSTRIAL - TRANSPORT - MARINE - OIL & GAS



SOUNDPROOFING SOLUTIONS FOR ALL INDUSTRIES
pyroteknc.com

Pyrotek.



MASS LOADED VINYL FOR ALL INDUSTRIES

The mass loaded vinyl (MLV) range has been uniquely developed by Pyrotek's world class engineering team. Offering superior acoustic transmission loss - Wavebar® and Quadzero™ are flexible reinforced noise barrier solutions that meet global market requirements in all industries including building, industrial, transport, marine and oil & gas.



Wavebar® is a reinforced MLV noise barrier designed by Pyrotek to meet market requirements and effectively reduce noise transmission. Due to its flexible and tear resistant properties, Wavebar is suitable for various applications across all industries, such as building, commercial, industrial and transport. Wavebar will help improve performance of a lightweight partition at critical frequencies.

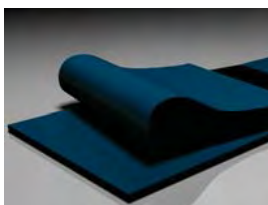

Wavebar® NC

Wavebar® NC is a tear resistant noise barrier curtain with high tensile strength. The tarpaulin base fabric facing is used to withstand tough weather conditions in addition to being UV resistant. Able to withstand exposure to most chemicals and solvents, Wavebar NC is easy to hang or drape in long lengths – being the ideal choice for outdoor use, oil and gas industries and construction sites. It can also be combined with absorption materials, offering versatility in challenging noise environments. The tarpaulin base fabric facing is available in various colours.

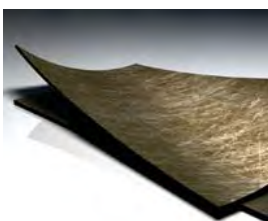

Wavebar® dBX

Wavebar® dBX is the latest alternative in noise barrier technology manufactured from thermoplastic recycled polymers. A self-extinguishing and low smoke emission noise barrier, Wavebar® dBX provides high-performance acoustic insulation that can be vacuum formed and easily moulded. This product is 100% recyclable and recommended for transport, building and industrial applications due to its strong characteristics.

Our Wavebar® and Quadzero™ range perform an important role as high-performance barriers where noise transmission issues need to be addressed. Typically stiff lightweight panels such as plasterboard, drywall, plywood and hollow core walls have a coincidence dip. A coincidence dip is the frequency at which the stiff panel vibrates in unison with the frequency of sound pressure waves. The frequency of the coincidence dip is dependent on the material's stiffness and internal damping properties causing a degradation in transmission loss. The Wavebar® and Quadzero™ range will eliminate the impact of the coincidence dip when installed in a structure, rendering it as a highly effective noise barrier.



BETTER FLEXIBILITY, EASY TO INSTALL

Quadzero™ is a flame resistant foil faced MLV offering superior acoustic transmission loss with high flame retardant properties. The reflective foil facing provides a low spread of flame surface covering for areas where higher fire specifications are required. Additionally, the dense, thin and strong physical characteristics make Quadzero suitable for building, industrial, transport and OEM sectors. It is also highly suitable for Liquid Natural Gas (LNG) pipe application.

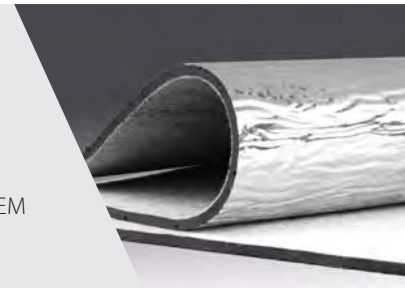

Quadzero™ NL is a foil faced barrier that is formulated to achieve the highest fire rating as an acoustic surface covering. It is durable, flexible and tear resistant, with a strong base fabric. This product offers optimum noise transmission loss with fire testing results that complies with international marine and rail standards. Quadzero NL is suitable for marine and rail carriages in walls, ceilings and under floor insulation, as it contains no ozone depleting substances, lead, unrefined oils or bitumen.

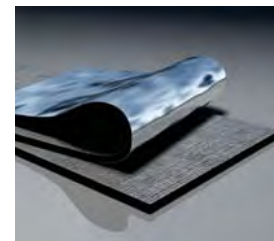

Quadzero™ NL

Quadzero™ dBX is a MLV laminated with reinforced aluminium foil, manufactured from thermoplastic recycled polymers that exhibits superior transmission loss. Meeting international standards for rail, transport and marine, Quadzero dBX has high fire resistant properties, a low spread of flame surface and low smoke development. This product is suitable for marine, transport and rail applications. Quadzero™ dBX is 100% recyclable.

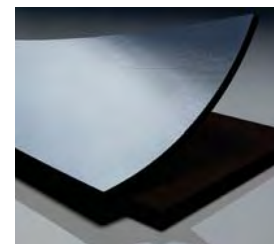

Quadzero™ dBX

TESTED TO A RANGE OF GLOBAL FIRE STANDARDS

Wavebar® is weather resistant, contains no ozone depleting substances and complies with International standards for Volatile Organic Compound (VOC) emissions.

IDEAL NOISE BARRIER SOLUTIONS FOR ALL MARKETS

Building and Commercial

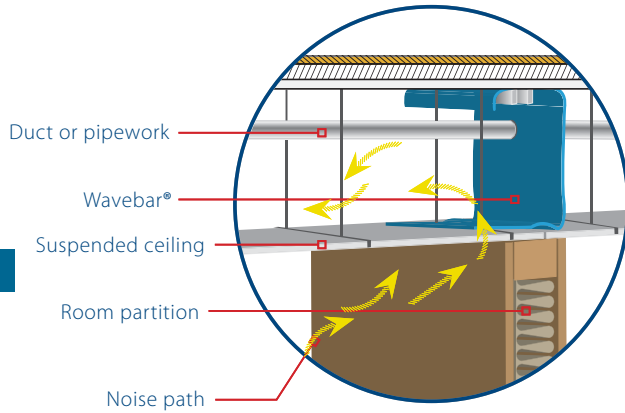

Wavebar® and Wavebar® dBX fitted in the plenum space above suspended ceilings and partition walls to avoid flanking noise.

Quadzero™ is suitable for ceiling cavities due to its reflective and low spread of flame surface covering.

Wavebar® fitted between plasterboard walls for greater transmission loss. Improves performance at critical frequencies generated from urban and environmental noise impact.

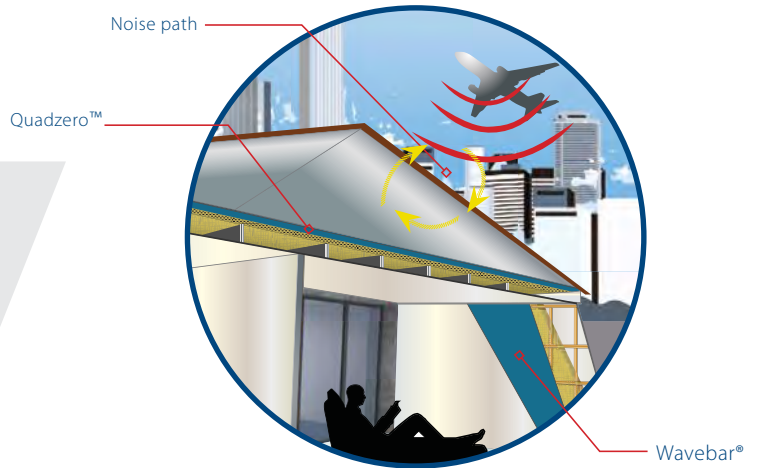

Transport

Quadzero™ NL and Quadzero™ dBX will effectively control sound transfer from external track, rail or engine noise into cabins and carriages. This durable product can be used without impacting carriage safety providing additional comfort to passengers.

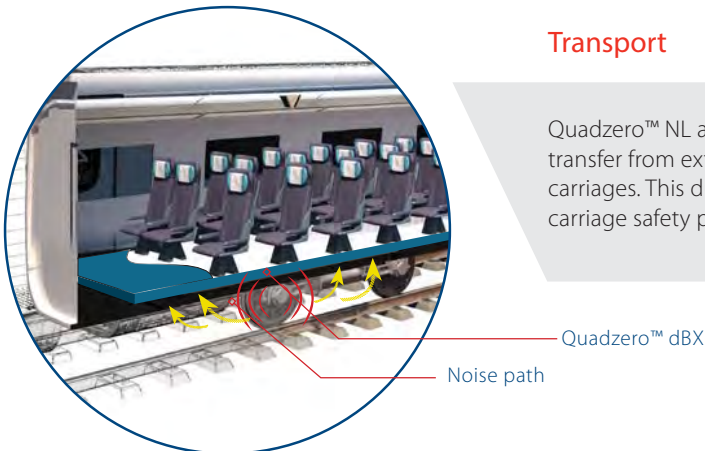

Marine

Quadzero™ NL and Quadzero™ dBX can be installed in the wall linings, deckheads and bulkheads of marine vessels to reduce sound transmission emitting from the vessel engine room.

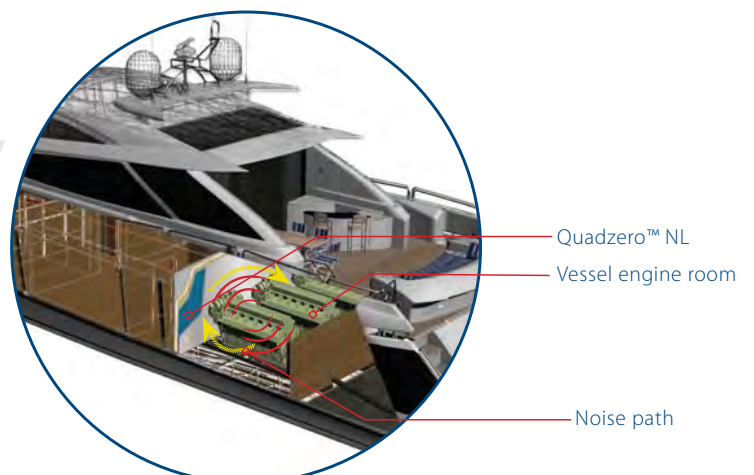

Industrial

Wavebar® NC can be conveniently draped over fencing as an acoustic barrier to reduce noise transmission around construction sites, building sites and mobile equipment.

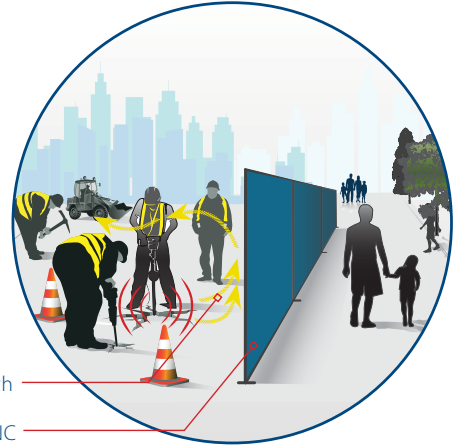

Noise path
Wavebar® NC

Wavebar® NC can be easily fabricated and sewn to make custom enclosures to reduce noise transfer from generator sets, plant rooms, printing machines and other heavy equipment.

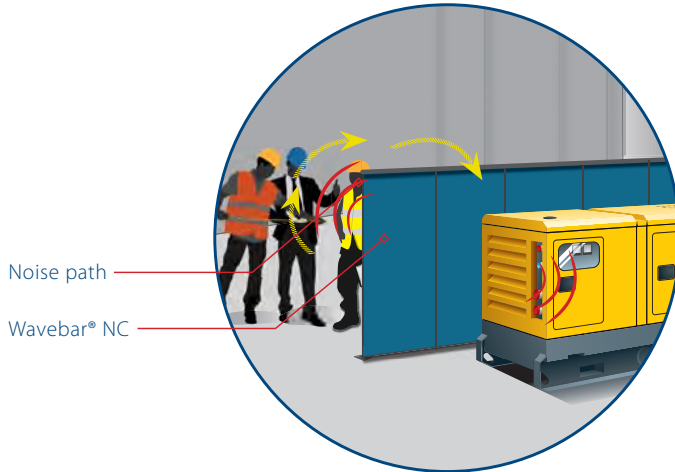

Noise path
Wavebar® NC

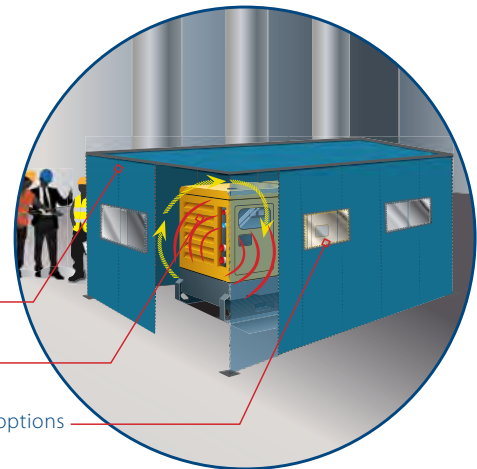

Wavebar® NC
Noise path
Modular panels and window options

LNG Pipes

Lagged around pipes, Wavebar® & Quadzero™ are important for LNG (Liquid Natural Gas) pipe applications to prevent noise breakout.

Wavebar® complies to the ISO 15665 (Group 2 Pipe size) test method.

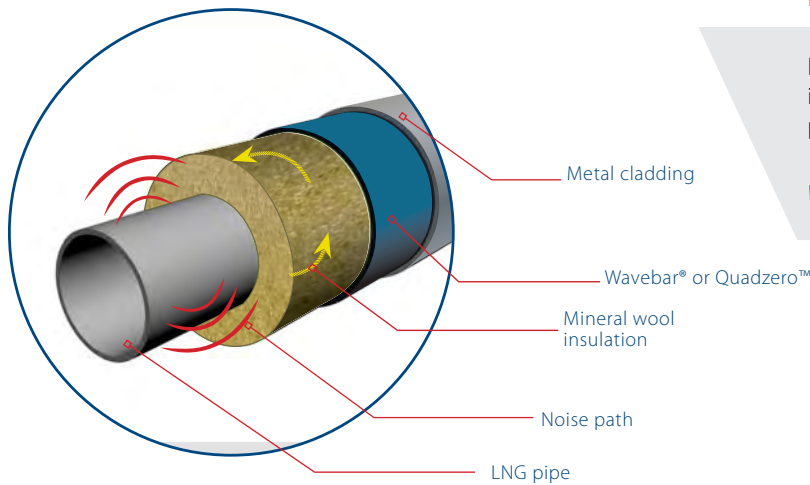

Pyrotek's Wavebar® & Quadzero™ range are available in various weights, widths, roll lengths and sheet sizes. Our MLV products are simple to cut and easy to install.



BUILDING

INDUSTRIAL

APPLICATIONS



Suited across a variety of applications, the mass loaded vinyl range offers superior acoustic transmission loss and complies to a range of international fire codes benefiting the following areas:

PRODUCT

TYPICAL AREAS OF USE

Wavebar®

- Home theatre and office partitions
- Inside cavities, over lightweight walls and ceilings
- Between the plenum chamber of a slab, the roof and adjoining partition walls

Wavebar® NC

- Noise curtain for indoor/outdoor industrial and construction sites
- Enclosures for industrial equipment e.g. generators, engine rooms, punch presses

Wavebar® dBX

- Automotive cabin
- Heavy transport and machinery
- Acoustic doors

Quadzero™

- Building construction
- LNG Pipes
- Roof cavities

Quadzero™ NL

- Train and tram carriages
- Marine deckheads and bulkheads
- Marine engine room

Quadzero™ dBX

- Train and tram carriages
- Marine engine room deck
- Inside cavities or over lightweight walls, ceilings and floor constructions



FEATURES

- Flexible and easy to install
 - Isolate cavities, over lightweight walls and ceiling constructions
 - Reinforced fabric strength
-
- Can be designed as a partial or complete enclosure around noise sources
 - Manufacturing options with stainless steel eyelets and hook-and-loop fasteners
 - Portable acoustic curtain easily draped over fencing
-
- Low smoke emission - contains no ozone depleting substances
 - Can be easily moulded into linings
 - Thermoplastic properties
-
- Fire resistant foil properties
 - Suitable for use with LNG pipes
 - Reflective foil faced surface
-
- Highest flame retardant properties
 - Self-extinguishes upon removal of flame
 - Aluminium foil faced surface
-
- Flame retardant properties
 - Reinforced aluminium facing
 - Suitable for use where thermoplastic materials are required

BENEFITS

- Reduces noise transfer through lightweight partition walls and ceilings
 - Reduce cross-talk noise and ensure privacy
 - Longevity
-
- Curtains are durable and address environmental noise impact
 - Customised for unique purposes and difficult sites
 - Reduce noise transmission around construction areas and mobile equipment on site
-
- Safe and self-extinguishes in heavy vehicle, road/engine bay
 - 100% recyclable
 - Rail carriage will hold its integrity for longer in case of emergency
-
- Acts as a noise and vapour barrier
 - Joins are easily taped for quick installation
 - Free from lead, odour producing oils and bitumen
-
- Suitable for use in high risk areas including marine & offshore
 - Meets international marine & rail standards
 - Used where high fire standards are required
-
- Durable with low spread of flame
 - 100% recyclable
 - Aluminium faced materials can be easily joined using foil tape

With over 40 years of noise control experience, Pyrotek® is a well trusted name for performance improving technical solutions.



pyroteknc.com

PYROTEK
WORLDWIDE LOCATIONS

AUSTRALIA

CANADA

CHINA

CZECH REPUBLIC

HONG KONG

INDIA

INDONESIA

JAPAN

KOREA

MALAYSIA

SINGAPORE

NEW ZEALAND

TAIWAN

THAILAND

TURKEY

UNITED ARAB EMIRATES

UNITED KINGDOM

UNITED STATES OF AMERICA

VIETNAM

CONTACT DETAILS

for further information please visit our website at pyroteknc.com

Pyrotek endorse forest sustainability and the preservation of natural environment. We procure the highest quality materials from suppliers who hold FSC (Forest Stewardship Council) Certification and PEFC (Programme for the Endorsement of Forestry Certification) amongst other certification programmes.

Caveats: Specifications are subject to change without notice. The data in this document are typical of average values based on tests by independent laboratories or by the manufacturer and are indicative only. Materials must be tested under intended service conditions to determine their suitability for purpose. The conclusions drawn from acoustic test results are as interpreted by qualified independent testing authorities. Nothing here releases the purchaser/user from responsibility to determine the suitability of the product for their project needs. Always seek the opinion of your acoustic or mechanical engineer on data presented by the manufacturer. Due to the wide variety of individual projects, Pyrotek is not responsible for differing outcomes from using their products. Pyrotek disclaims any liability for damages or consequential loss as a result of reliance solely on the information presented. No warranty is made that the use of this information or of the products, processes or equipment to which this information Page refers will not infringe any third party's patents or rights. DISCLAIMER: This document is covered by Pyrotek standard Disclaimer, Warranty and © Copyright clauses. See pyroteknc.com/disclaimer.

VIBRATION CONTROL



Decidamp® SP80 effectively **absorbs** and **dissipates vibrational energy** from the flexural stress of the base structure to reduce panel coincidence and resonance effects.

DECIDAMP® SP80

Decidamp® SP80 is a lightweight, non-toxic structural damping material that is suitable for exterior and interior use and anywhere that noise can impact structural longevity, comfort and function.



Features

- Advanced, Non-sag formulation
- Excellent adhesion to most surfaces
- Water based - non toxic, solvent free, low VOC
- Excellent flame resistance, ignition retardant
- Designed for damping across broad temperature and frequency range
- Reduces resonant vibration and eliminates tinniness and ringing
- Easy application and clean up (Sprayable)
- Can be painted/gel coated over, once cured
- Cures to chip resistant finish

Application

- Building: Metal roofing, floors wall cladding
- Enclosures for machinery and industrial equipment
- HVAC, plant rooms, substations
- Stainless steel applications (sinks, bowls)
- Garbage chutes and other utilities where suitable

Fast drying formula

Technical Datasheet



DECIDAMP® SP80

water-based vibration damping compound

Decidamp® SP80 is a fast drying, water-based viscoelastic vibration damping compound.

The advanced formula is optimised to suit building applications providing an acoustic improvement of structures that are exposed to vibrations and impact noise.

Developed with a special polymer technology, Decidamp® SP80 is a lightweight, non-toxic damping material that is suitable for exterior and interior use. It can be applied almost anywhere that vibration can impact structural longevity, comfort and function.

With exceptional fire properties and compliance to international fire codes, it performs across several industries and is now developed for building applications. Decidamp® SP80 is easy to apply by simply spraying, rolling or trowelling onto surfaces. Once dry, the cured film is UV, water and chip resistant and effectively damps vibration.

Decidamp® SP80 is a superior extensional damping compound and is suitable to be applied directly to structures (steel, fibreglass and alloys) where vibration damping is required.



applications

- Metal roofing, floors and wall cladding
- Enclosures for machinery and industrial equipment
- HVAC, plant rooms and substations
- Stainless steel applications (sinks, bowls)
- Hospital equipment
- Whitegoods and dishwashers
- Back of house, garbage chutes, and utilities
- LNG pipe

features

- Advanced, non-sag formulation
- Excellent adhesion to most surfaces
- Water-based, non-toxic, solvent-free, and low VOC
- Excellent flame resistance, ignition retardant
- Designed for damping across broad temperature and frequency range
- Reduces resonant vibration and eliminates tinniness and ringing
- Easy application and clean up (sprayable)
- Can be painted/gel coated over once cured
- Cures to a chip-resistant finish
- Fast drying formula

SPECIFICATIONS

Colour	Grey (standard colour) Other colours available depending on MOQ
Available	Pail: 20 kg, 5 gal
	Drum: 300 kg, 55 gal



PRODUCT SPECIFICATIONS

Colour	UOM	Weight	Service temp range (max short term)	pH	Chemical resistance			
Grey (Standard)	20 kg Pail	1.8 kg/m ² /mm DFT	-40 °C to 120 °C (-40 °F to 248 °F)	8	UV excellent	water very good	petrol good	diesel good
	5 gal Pail							
	300 kg (55 gal) Drum							

To achieve a desired dry film thickness (DFT), provision for material shrinkage of up to 15% on average should be included when applying wet coating.

When coating thickness requirement is not specified, general recommended coating thickness (dry film) is $\geq 1.0 \times T$ for steel, $\geq 0.5 \times T$ for aluminium, $\geq 0.3 \times T$ for FRP, where T = substrate thickness.

Other thicknesses may be installed to achieve desired damping performance.

Storage: Store between 10 °C to 45 °C (50 °F to 113 °F). Do not freeze.

Shelf Life: 24 months from receiving goods (stored under recommended conditions).

MATERIAL PROPERTIES

Test Method	Property	Report No.	Results
BS 476 Part 6	Fire propagation	376684	Complies with Class 0
BS 476 Part 7	Surface spread of flame	376685	
BS 476 Class 0 summary	Surface spread of flame Fire propagation	376686	
AS 1530.3	Flame Propagation (Spread of Flame Index), Smoke Development Index	21-005255	Complies with Australian Building Code Standards for other materials/locations/insulation materials. Spread of Flame Index = 4 Smoke Developed Index = 4
UL94	Flammability of plastic materials	29516AC1	HF-1, V-0
FMVSS-302	Flammability of interior materials	29516AC2	Complies to the requirements of US (DOT) Department of transportation for occupant compartments of motor vehicles
ISO 10140-2	Airborne noise insulation of 0.42 mm corrugated metal roofing with and without treatment of 1 mm (DFT) Decidamp SP80	T1822-1 & T1822-2	Untreated $R_w (C; C_{tr})/STC = 18 (-1; -2)/18$ Treated $R_w (C; C_{tr})/STC = 23 (-0; -2)/24$
ISO 10140-5	Rainfall noise insulation of 0.42 mm corrugated metal roofing with and without treatment of 1 mm (DFT) Decidamp SP80		Untreated $L_{JA} = 74.5$ Treated $L_{JA} = 64.3$
ISO 4624	Pull-off test for adhesion	33018BD	$\geq 0.68 \text{ N/mm}^2$



ACOUSTIC PERFORMANCE

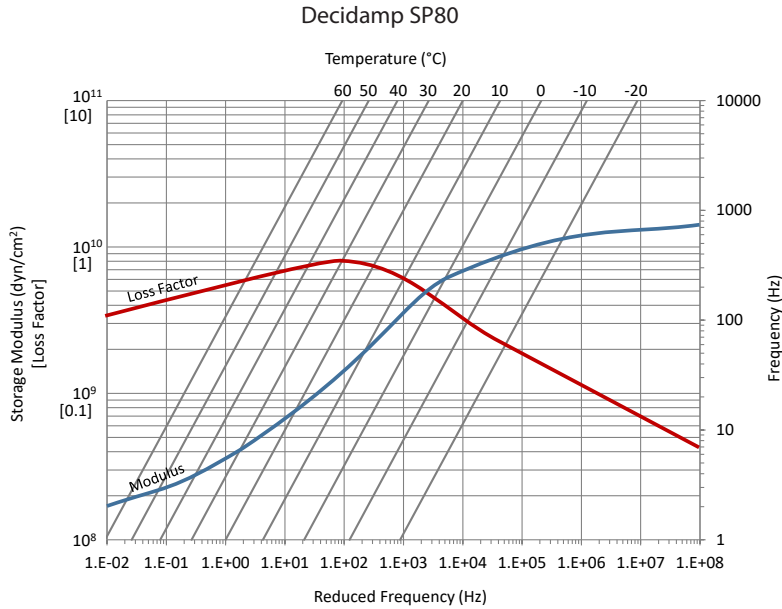

Tested to ISO 6721-5:1996
Report Number: 12716AR

How to read a reduced frequency nomogram:

1. Start by selecting the frequency (Hz) on the right-hand vertical axis.
2. Follow this value horizontally to the left to where the diagonal temperature isotherm intersects.
3. Draw a vertical line through the frequency and isotherm intersection, find the point where this line intersects the modulus and loss factor curves.
4. Draw horizontal lines from these points to the left-hand vertical axis to read the values.

ACOUSTIC DATA: SYSTEM LOSS FACTOR

Temperature (°C)	Application ratio of Decidamp® SP80 DFT on 1 mm steel (Product thickness: Substrate thickness)		
	1:1	2:1	3:1
15	0.07	0.23	0.38
20	0.04	0.15	0.24

Tested to ISO 6721-3:1994 | Report Number: 27818AR

For further information and contact details, please visit our website pyroteknc.com

Caveats: Specifications are subject to change without notice. The data in this document is typical of average values based on tests by independent laboratories or by the manufacturer and are indicative only. Materials must be tested under intended service conditions to determine their suitability for purpose. The conclusions drawn from acoustic test results are as interpreted by qualified independent testing authorities. Nothing here releases the purchaser/user from responsibility to determine the suitability of the product for their project needs. Always seek the opinion of your acoustic, mechanical and fire engineer on data presented by the manufacturer. Due to the wide variety of individual projects, Pyrotek is not responsible for differing outcomes from using their products. Pyrotek disclaims any liability for damages or consequential loss as a result of reliance solely on the information presented. No warranty is made that the use of this information or of the products, processes or equipment to which this Information Page refers will not infringe any third party's patents or rights. DISCLAIMER: This document is covered by Pyrotek standard Disclaimer, Warranty and © Copyright clauses. See pyroteknc.com/disclaimer.



Installation Guide



DECIDAMP® SP RANGE

Decidamp® SP range is a high-performance, fast drying, water-based, viscoelastic vibration damping compound specially formulated for easy application and maximum performance.



WORK HEALTH AND SAFETY

Gloves, protective goggles, respiratory protective equipment, protective clothing and any other appropriate safety equipment based on local health & safety requirements and safe work practice must be worn by the applicator.

KEY INSTALLATION REQUIREMENTS

Surface Preparation

This product is specially formulated to provide high adhesion to difficult substrates such as uncoated aluminium, however adequate surface preparation is essential.

- Remove any dust, dirt, oil, grease, rust, mould-release agent, etc. from the surface using a suitable solvent.
- Abrading the surface by wire brushing, sandblasting or abrasive paper is recommended for highly polished surfaces.
- On steel substrates, surface priming is recommended to prevent flash rusting.

METHODS OF APPLICATION

Decidamp® SP range can be applied using the following methods:

- **Trowel:** Simply apply and smooth as required.
- **Brush:** For brush applications, we recommend adding 0.3% of water by weight per kg of product. This will assist in easier and smoother application. Use a wide 100 mm (3.9 in) thick nylon bristle brush. Keep brush well loaded with Decidamp and use short strokes, applying a thick coat of approximately 2 mm (0.08 in). Avoid "painting" back and forth as this will cause the coat to become too thin.
- **Roller:** Used where high film build is not required, or for levelling and finishing an installation. Can be used to apply a final coat over surface defects. For roller applications, we recommend adding 1% of water by weight per kg of product. This will aid in an easier and smoother application. Using a short nap cloth roller, roll with short strokes, and try to avoid rolling back and forth, as this might cause the coat to become too thin. Use a light brush to "tip-off" the stipples if desired.
- **Air-assisted and Airless spray systems:** Please see page 3 for the recommended spray system for the application of Decidamp® SP range.

These advanced formulas were developed for acoustic improvement of structures that are exposed to vibration and impact.

The Decidamp SP range consists of highly-effective damping compounds that reduce vibration and minimise radiated structure-borne noise.

applications

- Marine: hulls, decks, deckheads and bulkheads
- Machinery and industrial equipment enclosures
- HVAC, plant rooms, substations
- Exit ways, smoking areas, stairwells
- Rail: locomotives, carriages, high-speed trains
- Automotive, trucks and bus underbodies
- Heavy earthmoving equipment
- Stainless steel applications (sinks, bowls)
- Hospital equipment
- Whitegoods and dishwashers
- Metal floors, deck roofing, wall cladding
- Garbage chutes

Trowel



Brush



Roller



Spray



Ensure proper preparation, mixing and application for best results. Decidamp® SP range should always be applied to surfaces that are clean, dry and free of contaminants.

MIXING & APPLICATION

- Mix thoroughly before application using a ribbon or paddle mixer as shown. The product should be mixed until it is a smooth, creamy consistency.
- If required, the viscosity of the product can be altered by the addition of 0.3% of water by weight per kg of product.
- Apply above ambient temperatures of 10 °C (50 °F).

APPLICATION RATE & COVERAGE

- Apply as a 2 mm (0.08 in) wet film thickness (WFT).
- Use of a tack coat is recommended: 0.5 mm (0.02 in) first coat.
- Decidamp SP150: Installation on maritime vessel to be done at maximum nominal thickness of 10 mm (0.4 in) DFT. Approved for use as paint systems on a metallic substrate with thickness of at least 3 mm (0.12 in).
- It is important to apply evenly to ensure proper curing and reduce waste.
- Use of thermometer, hygrometer or humidity meter is recommended for monitoring application conditions. High-temperature or low humidity conditions may lead to crack formation.
- Surface defects can be avoided by reducing applied wet film thickness to accommodate poor application conditions.
- Cracked coating can be remedied by application of an additional coat applied to the affected area.
- Excessively cold or high humidity conditions may lead to sagging. Assisted drying may be required.
- Ensure application is adequately dry before additional coating is added.
- Lower WFT application will have a faster drying time and will allow for a quicker re-coat time.
- The final thickness of the application will vary based on your requirement.

When the thickness requirement is unknown or not specified, the following is provided as a general guide:

- Dry coating thickness steel: >1.0 x substrate thickness.
- Dry coating thickness aluminium: >0.5 x substrate thickness.
- Dry coating thickness FRP: >0.3 x substrate thickness.

To achieve a desired dry film thickness, provision for material shrinkage of up to 15% on average should be included when applying wet coating.

Resistant to water spray or immersion up to 12 hours, however, if this is anticipated, Decidamp® SP range should always be sealed with a suitable commercial waterproof sealant/coating, applied well after complete curing of the material.

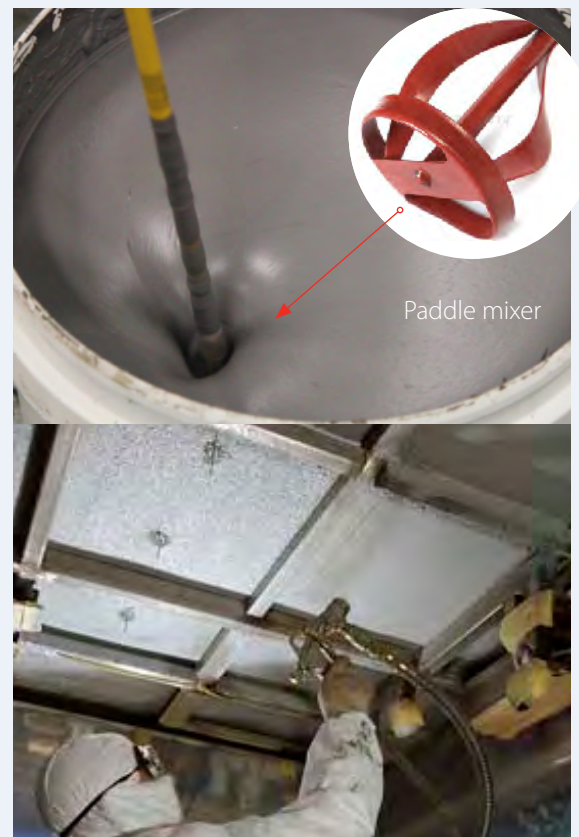

DRYING AND CURING

- For best results, allow the compound to dry naturally. Forced drying may result in cracking of the coat.
- In cold conditions, the substrate can be warmed to aid drying.
- Forced ventilation can be used to help coating dry. Air movement should be both in/out during drying process.
- It is recommended before install that a small section of the area is applied with the product to test and determine the adequacy of drying conditions.

The cure time of 2 mm Decidamp® SP80, SP150, SP450			
Temperature	Humidity	Dry to Touch	Fully Cured
20 - 25 °C (70 - 75 °F)	30 - 45%	2 to 3 hours	14 to 24 hours
26 - 30 °C (80 - 85 °F)	30 - 45%	1 to 2 hours	12 to 24 hours
31 - 36 °C (90 - 95 °F)	30 - 45%	1 to 2 hours	12 to 20 hours

Please note: drying and curing times are only general guides. Testing should be performed by the end user, as end-use conditions (thickness of application, substrate type, temperature and humidity) will affect drying times.

WET GAUGE FILM THICKNESS CHECK

To ensure the correct film build is achieved, a wet film gauge can be used (as shown on the right).

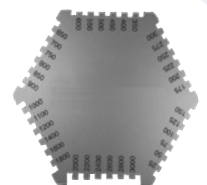

RECOMMENDED SPRAYING SETUPS

Below displays typical configurations - other configurations and settings can also be suitable

	Airless Spray System		Air-Assisted Spray System	
	Graco Xtreme 70:1 pneumatic pump	Wagner ProSpray 3.39	Pneumatic piston pump	Bottom entry pressure pot
Gun type	XTR-7 airless spray guns	Wagner Vector Pro or Grip airless gun	GNG/T3005 texture gun, bottom entry	GNG/T3005 texture gun, bottom entry
Operating line pressure <i>"Hose pressure rating to match requirement of pump"</i>	Typically 207 bar (3000 psi) for ¾" hose with up to 3.5m ³ /min airflow. <i>Higher pressure required for longer hose lengths.</i>	Up to 230 bar (3335 psi)	24 to 30 bar (350 to 440 psi)	2 to 4 bar (30 to 60 psi)
Length of hose from pump to gun	SP150, SP450 & SP500: Up to 30 m (98.4 ft) SP80 only: Up to 15 m (49.2 ft)	15m (50 ft)	Up to 30 m (98.4 ft)	5 to 20 m (16.4 to 65.6 ft)
Diameter of hose	9.5mm (3/8") ID	12.5 mm ID (1/2" ID)	19 mm ID (3/4" ID)	19 mm ID (3/4" ID)
Whip	0.5 m (1.6 ft) whip 6 mm (0.24 in) hose <i>Higher pressure required when whip used</i>	1 m x 9.5 mm (3.3 ft x 3/8 in.)	-	-
Diameter of nozzle	Reversible tips: 0.5 to 0.6 mm (0.02 to 0.02 in) (Reversible tips 519 to 523)	Reversible tip: 0.43 to 0.74 mm (0.017 to 0.029 in.)	2 to 6 mm (0.08 to 0.24 in)	2 to 6 mm (0.08 to 0.24 in)
Pump type	Ratio 70:1 piston pump	2.68 kW rated brushless DC motor	Ratio: 4:1 or greater Flow: 3 L/min 2-ball piston pump	20 litre (5 US gal) bottom entry pressure pot

PRODUCT INFORMATION

Product	Decidamp® SP80	Decidamp® SP150	Decidamp® SP450	Decidamp® SP500
Volume solids	70 - 75%	70 - 75%	70 - 75%	70 - 75%
Weight kg/m ² /mm	1.8 kg/m ² /mm DFT	1.6 kg/m ² /mm DFT	1.5 kg/m ² /mm DFT (1.6 g/ml wet)	1.3 kg/m ² /mm DFT
Consumption for 1 mm DFT <i>Includes allowance for up to 15% material shrinkage</i>	2.1 kg/m ²	1.85 kg/m ²	1.9 kg/m ²	1.5 kg/m ²
1 mm DFT (dry film thickness) coverage using 20kg pail	9.5 m ²	10.5 m ²	10.5 m ²	13 m ²

Substrates: Can be used on steel, aluminium, GRP/FRP laminate, GRP/FRP.

Water-resistant: Decidamp® SP range varieties are water-resistant, however, where regular exposure is expected, Decidamp® SP range should always be sealed with a suitable commercial waterproofing sealant/coating, applied well after complete curing of the material.

Shelf life and Storage:

- 24 months from receiving goods (when stored under recommended conditions).
- Product to be stored and transported between 10 to 45 °C (50 to 113 °F).
Do not allow to freeze.
- Partially used pails of the product can be reused if sealed firmly after first use.
- The opened product should be resealed and used within 2 months.
Frequent opening of the seal must be avoided.

Clean up and Safety:

- Equipment easily cleaned with water
- Personal Protection Equipment (PPE) including eye protection, gloves and safety clothing are highly recommended.

Please contact Pyrotek® for further information or detailed advice on your specific application.

GRACO XTREME 70:1 PNEUMATIC PUMP



XTR-7 Airless Spray Gun



GNG/T3005 Texture Gun Bottom Entry



Bottom Entry Pressure Pot



ProSpray 3.39



For further information and contact details, please visit our website pyroteknc.com

Caveats: Specifications are subject to change without notice. The data in this document is typical of average values based on tests by independent laboratories or by the manufacturer and are indicative only. Materials must be tested under intended service conditions to determine their suitability for purpose. The conclusions drawn from acoustic test results are as interpreted by qualified independent testing authorities. Nothing here releases the purchaser/user from responsibility to determine the suitability of the product for their project needs. Always seek the opinion of your acoustic, mechanical and fire engineer on data presented by the manufacturer. Due to the wide variety of individual projects, Pyrotek is not responsible for differing outcomes from using their products. Pyrotek disclaims any liability for damages or consequential loss as a result of reliance solely on the information presented. No warranty is made that the use of this information or of the products, processes or equipment to which this Information Page refers will not infringe any third party's patents or rights.
DISCLAIMER: This document is covered by Pyrotek standard Disclaimer, Warranty and © Copyright clauses. See pyroteknc.com/disclaimer.



ISOLATION CONTROL



Silentstep RU was developed to meet market noise reduction requirements in multistorey living, commercial, automotive and marine markets.

SILENTSTEP RU

Silentstep RU is a high-quality, impact underlay made from polymerically-bound recycled rubber. It has excellent sound impact attenuating properties for both new and old buildings.

Various densities and thicknesses are available to suit ceramic tiles, vinyl, carpet and timber flooring applications. Each density is specially engineered to meet specifiers' acoustical requirements.

Features

- Made from 100% recycled material
- No ozone-depleting substances are generated during manufacture
- Free from lead, odour-producing oils and bitumen
- Easily installed by quality carpet layers. No special tools or fixtures required
- Available in roll or sheet form, or custom made to suit (minimum order quantities apply)

Application

- Multistorey living areas constructed from lightweight materials with the intention to lay carpet
- Placed under solid timber or parquet flooring using Pyrotek's flooring systems - contact your local Pyrotek Representative

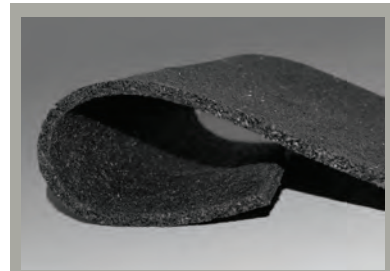

Silentstep RU can be installed on timber and concrete sub-bases and can be used in wet areas when installing in conjunction with an appropriate waterproofing membrane.

Roll size: All rolls are 1.2 m wide with various roll length options
Thicknesses: 3 mm, 4 mm, 5 mm, 8 mm, 10 mm Other thicknesses available on request

Higher density Silentstep RU products are recommended for ceramic tiles and vinyls to provide good stability under point loading.



A range of systems are available depending on application floor finish and substrates.

Technical Datasheet



SILENTSTEP® RU

soundproofing underlay for timber and tile flooring

Silentstep® RU is a high-quality, impact underlay made from polymerically-bound recycled rubber. It has excellent sound impact attenuating properties for both new and old buildings.

Various densities and thicknesses are available to suit ceramic tiles, vinyl, carpet and timber flooring applications. Each density is specifically engineered to meet specifiers' acoustical requirements.

Silentstep RU is suitable for all common construction and installation methods. It can be installed on timber and concrete sub-bases, and can be used in wet areas when installed in conjunction with an appropriate waterproofing membrane.



A range of systems are available depending on application floor finish and substrates.

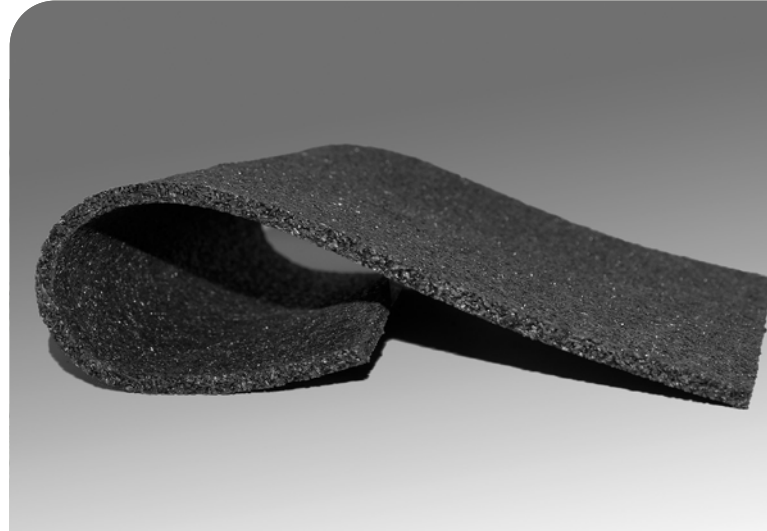

applications

- Multistorey living areas constructed from lightweight materials with the intention to lay carpet
- Placed under solid timber or parquet flooring using Pyrotek's flooring systems - contact your local Pyrotek Representative
- Marine vessels to stop engine noise travelling into staterooms, salons, VIP cabins etc
- Transport industry; under automotive, firewalls, wheel arches, boot mats, and transmission tunnels
- Motor homes and luxury motor coaches

SPECIFICATIONS

Density	Silentstep RU - 700 - min. 5mm 700 kg/m ³ Silentstep RU - 850 - min. 3mm 850 kg/m ³
Thicknesses	3 mm, 4 mm, 5 mm, 8 mm, 10 mm Other thicknesses available on request
Available	All rolls 1.2 m wide with various roll length options

NB: Higher density Silentstep RU products are recommended for ceramic tiles and vinyls to provide good stability under point loading.

features

- Made from 100% recycled material
- No ozone-depleting substances are generated during manufacture
- Free from lead, odour-producing oils and bitumen
- Easily installed by quality carpet layers. No special tools or fixtures required
- Available in roll or sheet form, or custom made to suit (minimum order quantities apply)



ACOUSTIC PERFORMANCE

Floor System	Acoustic Underlay	Test Reference	ΔLw	Ln,w	IIC
Bare 150 mm concrete slab	None	INR157	0	80	27
10 mm ceramic tile	5 mm Silentstep RU Cork/Rubber 720	INR157: K	13	67	43
10 mm ceramic tile	6 mm Silentstep RU 700	INR157: L	14	66	44
8 mm ceramic tile	3 mm Silentstep RU 850	INR163: C	16	64	46
19 mm timber + 15 mm plywood	5 mm Silentstep RU 700	INR157: D	16	63	48
14 mm timber	3 mm Silentstep RU Cork/Rubber 720	INR157: G	16	62	48
8 mm ceramic tile	10 mm Silentstep RU 850	INR163: B	17	62	48
14 mm timber	3 mm Silentstep RU 850	INR157: I	17	62	49
14 mm timber	3 mm Silentstep RU 850	INR157: H	16	61	49
10 mm ceramic tile + 20 mm screed	5 mm Silentstep RU Cork/Rubber 720	INR157: N	17	60	50
14 mm timber	5 mm Silentstep RU 700	INR157: F	18	60	50
10 mm ceramic tile + 20 mm screed	5 mm Silentstep RU 700	INR157: M	18	59	51
14 mm timber	3 mm Silentstep RU 850	INR157: A	18	59	51
8 mm laminate timber	3 mm Silentstep RU 850	INR157: B	18	59	51
19 mm timber + 15 mm plywood	15 mm Silentstep RU 600	INR157: E	18	58	52
2 mm vinyl plank	3 mm Silentstep RU Cork/Rubber 720	INR157: C	20	57	53
2 mm vinyl + 5 mm masonite	3 mm Silentstep RU 850	INR157: J	22	54	56

Tested to ISO 140-8:1997 at CSIRO, Australia

Report Number: INR157 & INR163

Note: All flooring systems were installed onto a 150 mm thick steel reinforced concrete slab. No ceiling was installed beneath, therefore even higher results can be achieved with the addition of a ceiling system (the value of which depends on the specific ceiling system employed). The table above serves as a summary, the full floor systems are detailed in the reports.

PHYSICAL PROPERTIES:

Tear resistance 3.1N/mm²

(ISO 4674.1-2003 (E))

Hardness (Shore A) 50.0

(ASTM D2240-2003)

Elongation at break 37.5 (AS2001.2.3.2-2001)

Temperature range - 25°C to 80°C

HEALTH AND SAFETY:

Silentstep RU is non-toxic and safe to handle by methods prescribed in the Safety Data Sheet.

For further information and contact details, please visit our website pyroteknc.com

Caveats: Specifications are subject to change without notice. The data in this document is typical of average values based on tests by independent laboratories or by the manufacturer and are indicative only. Materials must be tested under intended service conditions to determine their suitability for purpose. The conclusions drawn from acoustic test results are as interpreted by qualified independent testing authorities. Nothing here releases the purchaser/user from responsibility to determine the suitability of the product for their project needs. Always seek the opinion of your acoustic or mechanical engineer on data presented by the manufacturer. Due to the wide variety of individual projects, Pyrotek is not responsible for differing outcomes from using their products. Pyrotek disclaims any liability for damages or consequential loss as a result of reliance solely on the information presented. No warranty is made that the use of this information or of the products, processes or equipment to which this Information Page refers will not infringe any third party's patents or rights. DISCLAIMER: This document is covered by Pyrotek standard Disclaimer, Warranty and © Copyright clauses. See pyroteknc.com/disclaimer.



Installation Guide



SILENTSTEP RU

The Silentstep RU installation guide provides recommendations to maximise the service life in various applications.

WORK HEALTH AND SAFETY

Appropriate safety equipment such as gloves, protective goggles, protective clothing or any other PPE based on local health & safety requirements must be worn by the applicator.

KEY INSTALLATION REQUIREMENTS

Note: other adhesive can be used. It is recommended to conduct a trial if alternative adhesives are used. The installer should seek the advice of the glue supplier before application.

- Roll out Silentstep RU 24 hours prior to cutting to allow the material to relax and acclimatise for easier handling.
- It is recommended to keep the rolls between 18 °C and 24 °C or at the ambient room temperature for 24 hours prior to installation.
- Silentstep RU must be installed in the same direction and allowed to relax unrolled for a minimum of two hours before cutting or adhering.
- The floor type that Silentstep RU is to be adhered to must be dry, clean, smooth, and surface evenly levelled. It must also be free of oil, grease, fat, curing compounds, old adhesive residue, paint, wax, sealers etc. that can affect installation or performance.
- If specified, then the rolls must be adhered to the sub-base using only the specified adhesive. A concrete moisture test should be carried out to make sure the floor is dry (below 5.5%) and meets the manufacturers specifications.
- Once the subfloor is prepared, establish your starting point by rolling out one Silentstep RU roll vertically [long seams to go with the traffic flow where possible] and position it against the wall and/or square with the desired run configuration. Continue to roll out for the entire installation that is to be adhered or laid in the one day. Lengths can be trimmed in position if required. All seams are to be butt jointed using the precision cut factory edges.
- To apply adhesive, fold the first sheet to be glued in half-length ways. Apply the adhesive as per manufacturers specifications. Carefully roll the sheet back down into the wet adhesive ensuring that no air is trapped underneath.
- Immediately ensure proper contact with the adhesive by rolling the floor with a flooring roller. Next roll back the other half of the first sheet and half of the adjoining sheet and apply adhesive.
- Continue repeating the rolling in of the sheet and application of the adhesive as previous and for the remaining area.

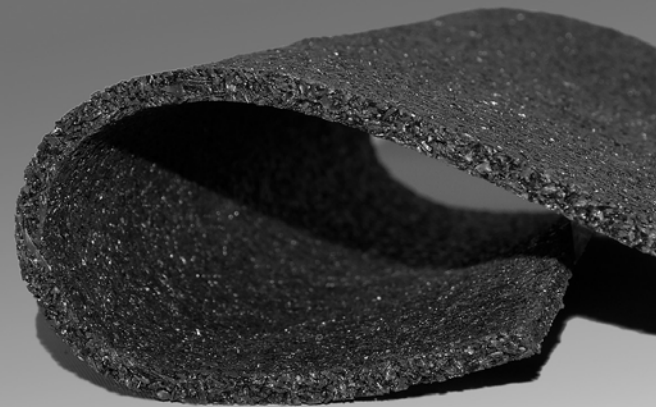

Silentstep RU is suitable for all common construction and installation methods. It can be installed on timber and concrete sub-bases and can be used in wet areas when installing in conjunction with an appropriate waterproofing membrane.

applications

- Multistorey living areas constructed from lightweight materials with the intention to lay carpet
- Placed under solid timber or parquet flooring using Pyrotek's flooring systems - Please contact your local Pyrotek representative for more information
- Marine vessels to stop engine noise travelling into staterooms, salons, VIP cabins etc.
- Transport industry: under automotives, firewalls, wheel arches, boot mats, and transmission tunnels
- Motorhomes and luxury motor coaches



APPLICATION GUIDELINES FOR SILENTSTEP RU – 700 - ACOUSTIC UNDERLAY

The 700 density of Silentstep RU is suited for ceramic installations where a screed bed is required over the acoustic underlay.

CERAMIC TILE FLOORING OVER SCREED BED WITH SILENTSTEP RU (700)

Silentstep RU - butt joined and cut to cover area required.

Ceramic tile Fully adhered using approved tile adhesive. Installed to manufacturer's specifications or direct bond on screed.

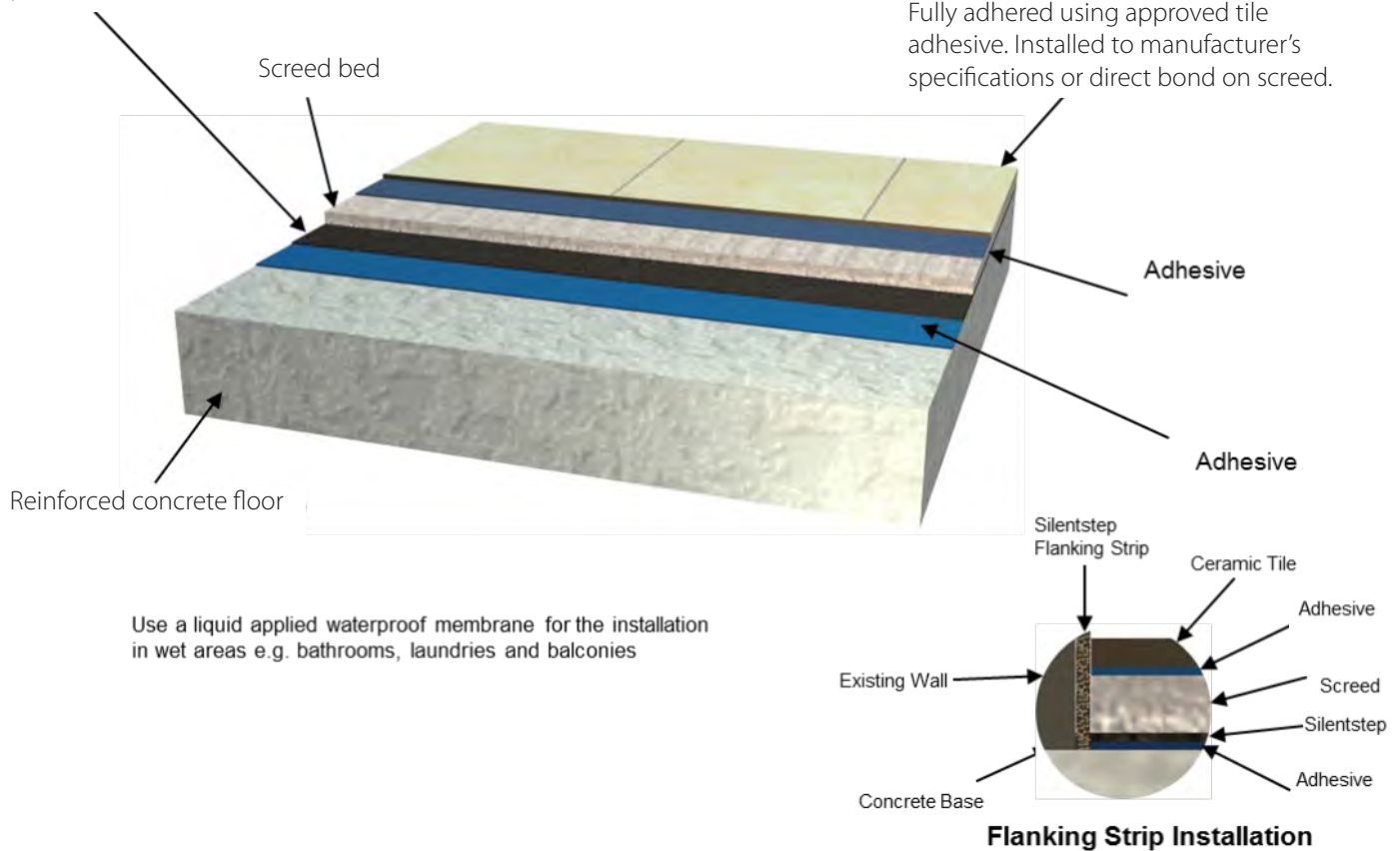

Use a liquid applied waterproof membrane for the installation in wet areas e.g. bathrooms, laundries and balconies

APPLICATION GUIDELINES FOR SILENTSTEP RU – 700 - ACOUSTIC UNDERLAY

We recommend flanking strips be sandwiched between the wall and floor covering, overhanging the top of the floor, covered by skirting boards and silicon beading. Flanking strips can be pre-fabricated upon request with specific measurements, or excess Silentstep RU material can be cut and used for this application.

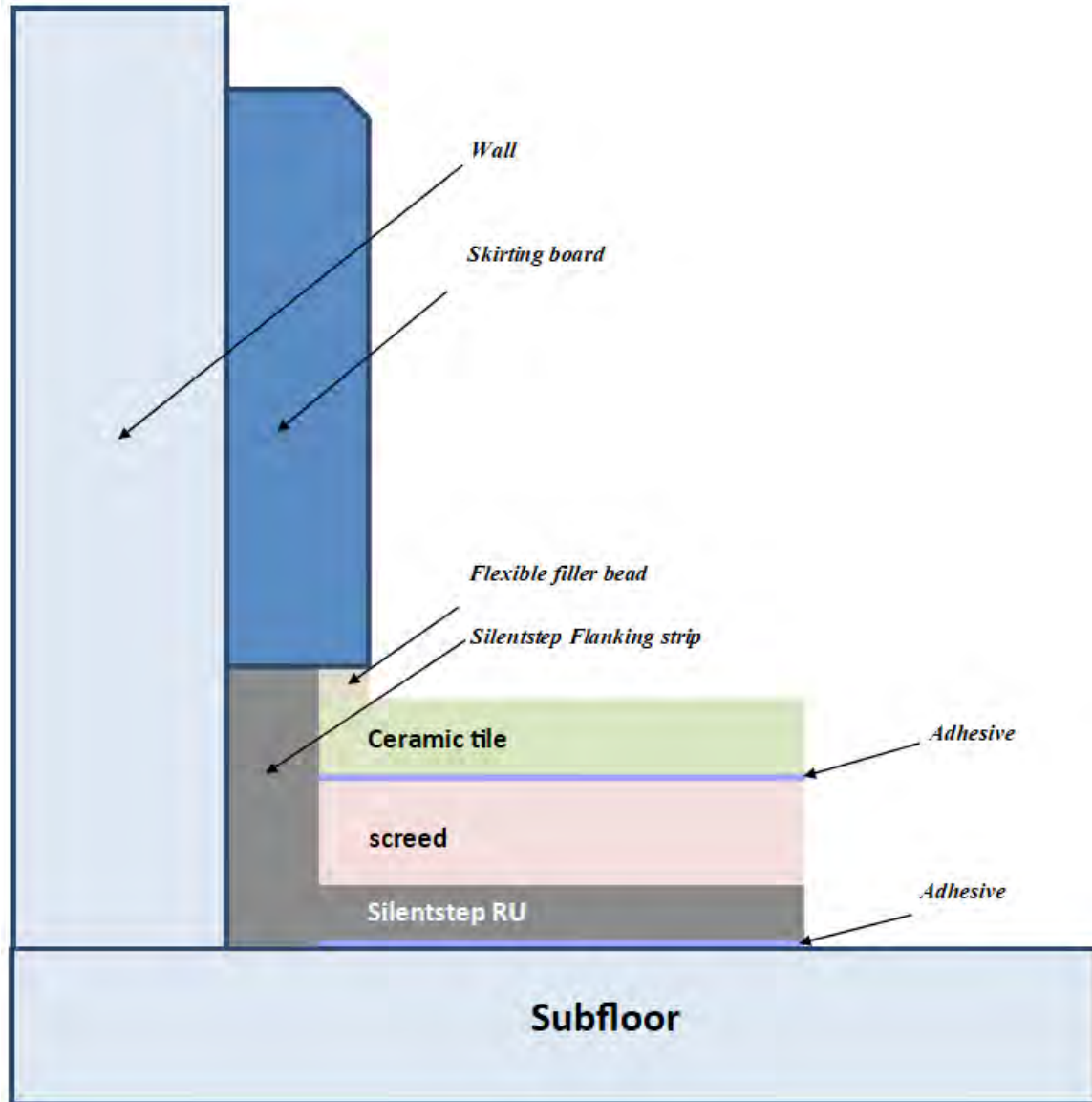

Please contact Pyrotek® for further information or detailed advice on your specific application.

ANTI-CONDENSATION TEMPERATURE REDUCTION

Decicoat™ T35 is a water-based spray-on thermal insulation coating specially formulated with anti-condensation and corrosion protection properties. It also complies to international fire codes for building, rail and marine applications.

Why Decicoat™ T35?

Condensation is associated with relative humidity, air pressure and occurs when temperature differentials between two areas pass over the 'dew point' threshold. **Decicoat™ T35** regulates surface temperatures of the component by inhibiting thermal transfer to effectively control the onset of condensation when applied with the appropriate coating thickness.

Features

- Thermal insulation, excellent anti-condensation and corrosion protection
- Lightweight, non-sag formulation with excellent adhesion to various metal substrates
- Complies to international standards for low spread of flame, smoke and toxicity
- Water-based compound – no volatile solvents or thinners required for cleaning (low odour environment)
- No primer required - easy, fast and seamless application
- Sprayable - air gun or airless spray system
- Long-lasting, cures to a hard chip, UV and moisture-resistant finish
- Can be used in conjunction with other insulation materials

Application

- Applications exposed to high humidity and temperature fluctuations such as: pipes, walls or building interiors
- Underside of metal deck roofing and metal wall cladding
- Applied in conjunction with traditional fibrous or foam insulation to improve overall thermal insulation systems



Decicoat™ T35

can be used as an independent solution, or to complement other insulation materials. This adds protection from condensation and corrosion while maintaining the overall thermal performance



Technical Datasheet



DECICOAT™ T35

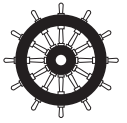

0575

water-based, sprayable thermal coating

Decicoat T35 is a water-based spray-on thermal insulation coating specially formulated with anti-condensation and corrosion protection properties. It has been developed to meet market requirements in the rail, off-shore, marine, chemical, petroleum, automotive and construction industries.

Unlike traditional insulation materials like glass wool or mineral fibre, Decicoat T35 provides a seamless and sprayable application with 100% coverage. This means Decicoat T35 successfully prevents thermal bridging.

With excellent adhesion to most metals, Decicoat T35 bonds flush with substrates even around uneven surfaces. Depending on the application requirement, it can be used as an independent solution, or to complement other insulation materials, when added protection from condensation and corrosion are required for overall thermal performance.

Condensation is associated with relative humidity, air pressure and occurs when temperature differentials between two areas pass over the 'dew point' threshold. With the right coating thickness, Decicoat T35 regulates surface temperatures of the component by inhibiting thermal transfer to effectively control the onset of condensation.

Near odourless, it complies with international fire codes for rail and marine applications, exhibiting a low spread of flame, low heat release, low toxicity and low smoke release during combustion.



applications

- Marine vessels: interiors of superstructures and hulls in workboats, luxury yachts and super-liners.
- Rail applications: carriage ceiling and walls
- Industrial: on the underside of metal deck roofing, metal wall cladding or shipping containers
- Applications exposed to high humidity and temperature fluctuations
- Oil & gas/offshore: interior structures of habitable areas and LNG pipelines
- Automotive: heavy vehicles, buses, trailers, tractors
- Applied in conjunction with traditional fibrous or foam insulation to improve overall thermal insulation systems
- Domestic: pipes, walls, interiors

SPECIFICATIONS

Colour	White
Available	Pail: 19 L, 5 gal
	Drum: 200 L

features

- Thermal insulation, excellent anti-condensation and corrosion protection
- Eliminate thermal bridging
- Complies to international standards - low spread of flame, smoke and toxicity
- Manufactured under ISO 9001 Quality Systems
- Use in conjunction with other insulation materials
- Decrease interior sound levels by damping panel resonance
- Lightweight, non-sag formulation with excellent adhesion to various metal substrates
- Long-lasting, cures to a hard chip, UV and moisture-resistant finish
- Water-based compound – no volatile solvents or thinners required for cleaning - low odour environment
- No primer required - easy, fast and seamless application
- Sprayable - air gun or airless spray system

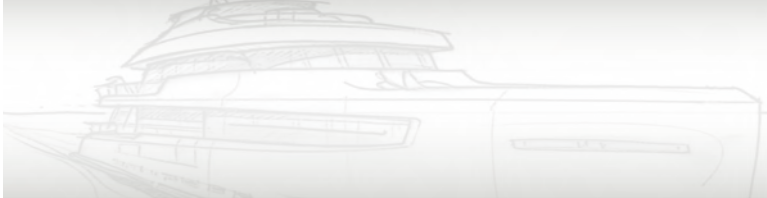

PRODUCT SPECIFICATIONS

Colour	UOM	Weight	Consumption for 1 mm (0.04 in) DFT. Includes allowance for up to 10% material shrinkage	Service temp range (max short term)	Application guidance
White	19 L (5 gal) pail	0.39 kg/m ² /mm DFT (0.08 lb/ft ² /mm DFT)	1.1 L/m ² (0.027 gal/ft ²)	-40 °C to 120 °C (-40 °F to -248 °F)	Minimum recommended application: 0.5 mm DFT General purpose installation: 2 mm DFT Other thicknesses as per specification or requirement
	200 L drum				

To achieve a desired dry film thickness, provision for material shrinkage of up to 10% on average should be included when applying a wet coating.

Storage: Store between 10 °C to 45 °C (50 °F to 113 °F).

Shelf Life: 24 months from receiving goods (stored under recommended conditions).

MATERIAL PROPERTIES

Test method	Property	Report	Results
IMO FTP Part 5	Surface flammability	376675	Complies for Bulkhead, walls and ceiling linings up to 2 mm thickness on metallic substrate. USCG Type approval granted.
IMO FTP Annex 2	Smoke and toxicity	376675	
MED B	EC Type Certificate (Module B) for Marine Equipment Directive	MEDB00007RS	
MED D	EC Type Certificate (Module D) for Marine Equipment Directive	MEDD000028J	
EN 45545-2 (ISO 5658-2)	Spread of flame	503991	R1, R7, R8, HL3
EN 45545-2 (ISO 5660-1 : 50kWm-2)	Heat release rate by cone calorimeter	503995	
EN 45545-2 (ISO 5659-2 : 50kWm-2)	Smoke generation (optical density)	503993	
RISSB AS 7529	Material fire performance	376677, 376678, 376679	Complies with requirements for combustible component material in Locomotive and Passenger rolling stock.
ASTM E 162	Surface flammability	101731845MID-001c	Complies for US (FRA) Federal railroad administration requirements and requirements of NFPA 130 - Complies for US (DOT) Department of transportation requirements for acoustic insulation of transit bus and vans (Docket 90A).
ASTM E 662	Optical Density of Smoke Generated	101731845MID-002c	
ASTM E 800 (SMP-800C)	Gases Present or Generated During Fires	101731845MID-003c	
FMVSS 302	Flammability of interior materials	20713JY	Complies to the requirements of US (DOT) Department of transportation for occupant compartments of motor vehicles.



CHEMICAL RESISTANCE

UV	Water	Petrol	Diesel	10% HCl solution	10% NaOH solution	Permeability (ASTM1653) (Report no. 19013BD1)
2000+ hours	Excellent	Good	Good	Good	Good	< 3 metric perms

THERMAL PERFORMANCE

Thermal conductivity (ISO 8302) (Report no. 332/13)
0.07 Wm ⁻¹ K ⁻¹

Surface temperature comparison with radiated heat

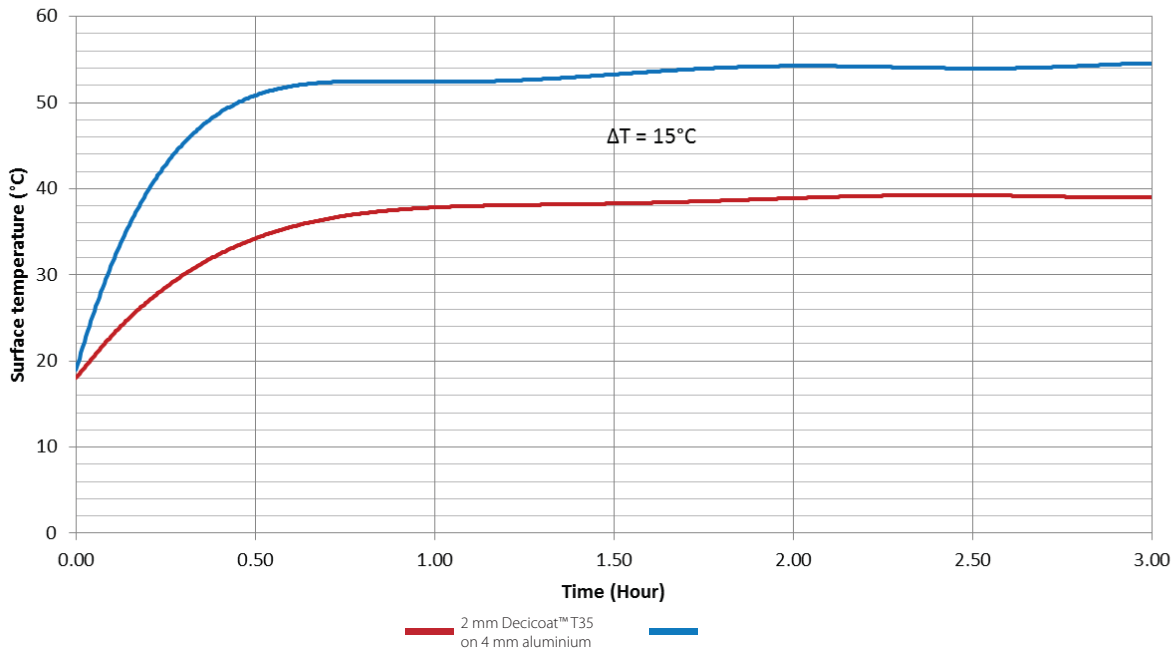

Report no.20613BD1



ACOUSTIC PERFORMANCE

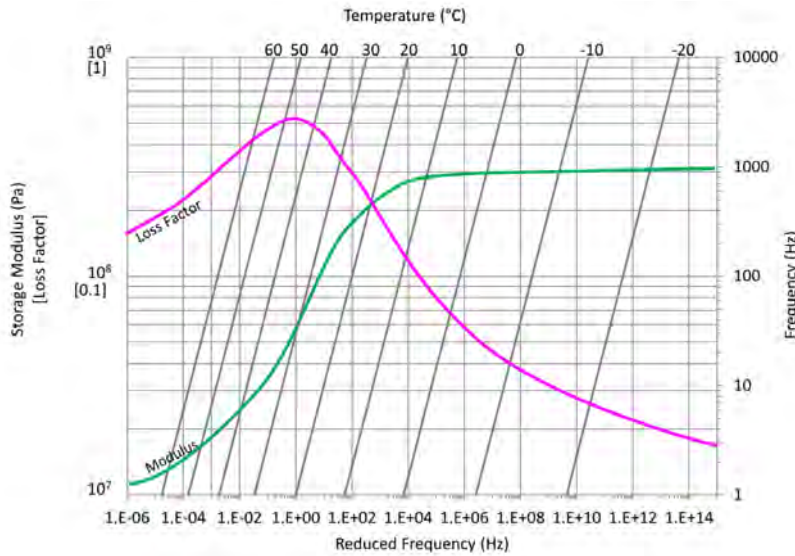

Tested to ISO 6721-5:1996
Report Number: 06424CD

How to read a reduced frequency nomogram:

1. Start by selecting the frequency (Hz) on the right-hand vertical axis.
2. Follow this value horizontally to the left to where the diagonal temperature isotherm intersects.
3. Draw a vertical line through the frequency and isotherm intersection, find the point where this line intersects the modulus and loss factor curves.
4. Draw horizontal lines from these points to the left-hand vertical axis to read the values.

SYSTEM LOSS FACTOR

Temp (°C)	SLF at 2:1 Ratio on Steel	Noise reduction (dB) on a large panel	SLF at 2:1 Ratio on aluminium	Noise reduction (dB) on a large panel
-10	0.013	11.21	0.026	14.22
0	0.013	11.21	0.026	14.22
10	0.018	12.50	0.036	15.51
20	0.037	15.68	0.074	18.69
30	0.028	14.47	0.056	17.48
40	0.021	13.22	0.042	16.23
50	0.019	12.72	0.037	15.73

Test report: 34623CD

DECAY RATE AS PER ISO 7626-5:1994

Sample	Decay Rate (dB/sec)
1 mm steel	38
1mm steel with 2mm Decicoat T35 coating	3500

Test report: 20613BD1

Conversion of system loss factor to estimated noise reduction on the large panel (dB) over range of temperatures as tested to ASTM E756-83. The system being a ratio 2:1 coating to steel/aluminium substrate.

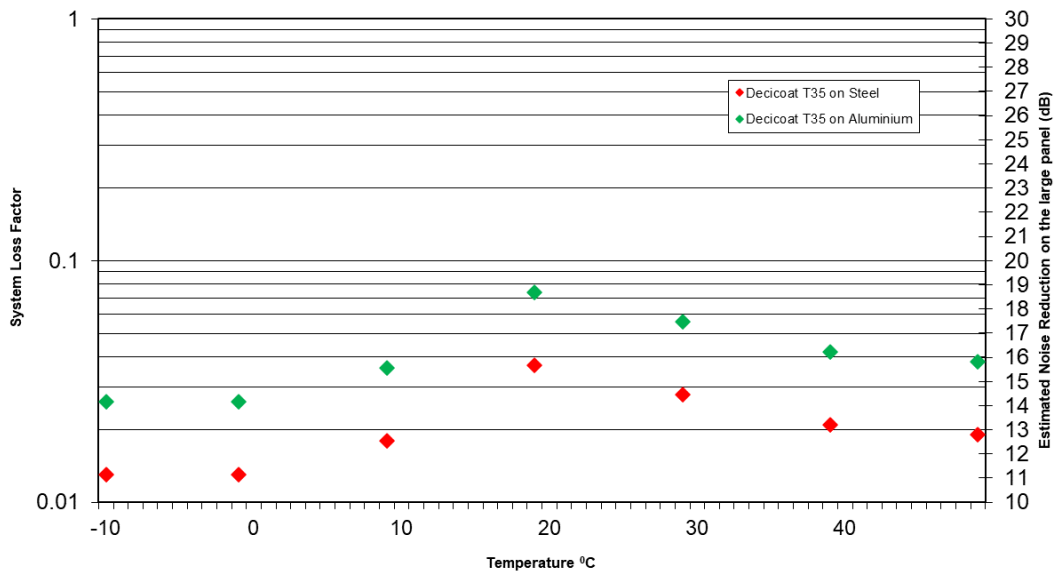

For further information and contact details, please visit our website pyroteknc.com

Caveats: Specifications are subject to change without notice. The data in this document is typical of average values based on tests by independent laboratories or by the manufacturer and are indicative only. Materials must be tested under intended service conditions to determine their suitability for purpose. The conclusions drawn from acoustic test results are as interpreted by qualified independent testing authorities. Nothing here releases the purchaser/user from responsibility to determine the suitability of the product for their project needs. Always seek the opinion of your acoustic, mechanical and fire engineer on data presented by the manufacturer. Due to the wide variety of individual projects, Pyrotek is not responsible for differing outcomes from using their products. Pyrotek disclaims any liability for damages or consequential loss as a result of reliance solely on the information presented. No warranty is made that the use of this information or of the products, processes or equipment to which this Information Page refers will not infringe any third party's patents or rights. **DISCLAIMER:** This document is covered by Pyrotek standard Disclaimer, Warranty and © Copyright clauses. See pyroteknc.com/disclaimer.



Installation Guide



DECICOAT™ T35

This installation guide provides recommendations to maximise the service life in various applications. Decicoat™ T35 is a water-based thermal insulation compound that is simple to apply using a range of spray systems.



WORK HEALTH AND SAFETY

Gloves, protective goggles, respiratory protective equipment, protective clothing and any other appropriate safety equipment based on local health & safety requirements and safe work practice must be worn by the applicator.

KEY INSTALLATION REQUIREMENTS

Surface Preparation

This product is specially formulated to provide high adhesion to difficult substrates such as uncoated aluminium, however adequate surface preparation is essential.

- Remove any dust, dirt, oil, grease, rust, mould-release agent, etc. from the surface using a suitable solvent.
- Abrading the surface by wire brushing, sandblasting or abrasive paper is recommended for highly polished surfaces.
- On steel substrates, surface priming is recommended to prevent flash rusting.

METHODS OF APPLICATION

Decicoat T35 can be applied using the following methods:

- **Trowel:** Simply apply and smooth as required.
- **Brush:** For brush applications, we recommend adding 0.3% of water by weight per kg of product. This will assist in easier and smoother application. Use a wide 100 mm (3.9 in) thick nylon bristle brush. Keep brush well loaded with Decicoat T35 and use short strokes, applying a thick coat of approximately 2 mm (0.08 in). Avoid "painting" back and forth as this will cause the coat to become too thin.
- **Air-assisted and airless spray systems:** Please see page 3 for the recommended spray system for the application of Decicoat T35 range.

Trowel



Brush



Spray



Decicoat T35 is a water-based spray-on thermal coating specially formulated to provide an anti-condensation solution.

The product is designed to be installed in industries such as rail, offshore, marine, and automotive.

applications

- Rail: locomotive and passenger rolling stock (interiors, floors, cabin)
- Industrial: underside of metal deck roofing and metal wall cladding
- Offshore platforms: interior structures of habitable areas
- Automotive: heavy vehicles, buses, trailers, and tractors
- In conjunction with traditional fibrous insulation



Ensure proper preparation, mixing and application for best results. Decicoat T35 range should always be applied to surfaces that are clean, dry and free of contaminants.

MIXING & APPLICATION

- Mix thoroughly before application using a ribbon or paddle mixer as shown. The product should be mixed until it is a smooth, creamy consistency.
- The pail can be placed upside down for 24 hours before use or opening to make mixing easier.
- Apply above ambient temperatures of 10 °C (50 °F).
- If required, the viscosity of the product can be altered by a maximum of 2% addition of water. Application testing performed under end-use conditions is required for water additions greater than 2%.

APPLICATION RATE & COVERAGE

- The minimum dry film thickness (DFT) should be 0.5 mm (0.02 in).
- A DFT of 2 mm (0.08 in) is recommended when applied to a system.
- Each coating should be 0.5 mm (0.02 in) to 1 mm (0.04 in) thick.
- Installation on maritime vessel to be done at recommended nominal thickness of 2.5 mm (0.1 in) DFT. Approved for use as paint systems on a metallic substrate with thickness of at least 2.25 mm (0.09 in).
- Additional thickness can be applied to achieve the desired result. The final thickness of the application will vary based on your requirement.
- When applied, thicker applications (as a single coat) are possible but will require longer drying time.
- To achieve the desired dry film thickness, provision for material shrinkage of up to 10% on average should be included when applying the wet coating.
- Use of a tack coat is recommended for the first 0.5 mm (0.02 in) coating.
- It is important to apply evenly to ensure proper curing and to reduce waste.
- Use of thermometer, hygrometer or humidity meter is recommended for monitoring application conditions. High-temperature or low humidity conditions may lead to crack formation.
- Surface defects can be avoided by reducing applied wet film thickness (WFT) to accommodate poor application conditions.
- A cracked coating can be remedied by application of an additional coat applied to the affected area.
- Excessively cold or high humidity conditions may lead to sagging. Assisted drying may be required.
- Ensure application is adequately dry before any additional coating is added.
- Lower WFT application will have a faster drying time and will allow for a quicker recoat time.



DRYING AND CURING

- For best results, allow the compound to dry naturally. Forced drying may result in cracking of the coat.
- In cold conditions, the substrate can be warmed to aid drying.
- Forced ventilation can be used to help coating dry. Air movement should be both in/out during drying process.
- It is recommended before install that a small section of the area is applied with the product to test and determine the adequacy of drying conditions.

Drying time	
Initial drying 1 mm	1 hour
Initial drying 2 mm	4 to 6 hours
Completely dry	24 to 72 hours

Please note: drying and curing times are only general guides. Testing should be performed by the end user, as end-use conditions (thickness of application, substrate type, temperature and humidity) will affect drying times.

WET GAUGE FILM THICKNESS CHECK

To ensure the correct film build is achieved, a wet film gauge can be used (as shown on the right).

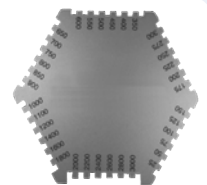

RECOMMENDED SPRAYING SETUPS

Below displays typical configurations - other configurations and settings can also be suitable

	Airless Spray System		Air-Assisted Spray System	
	Graco Xtreme 70:1 pneumatic pump	Wagner ProSpray 3.39	Pneumatic piston pump	Bottom entry pressure pot
Gun type	XTR-7 airless spray guns	Wagner Vector Pro or Grip airless gun	GNG/T3005 texture gun, bottom entry	GNG/T3005 texture gun, bottom entry
Operating line pressure <i>"Hose pressure rating to match requirement of pump"</i>	Typically 138 to 207 bar (2000 to 3000 psi). Higher pressure required for longer hose lengths	Up to 230 bar (3335 psi)	Max. 30 bar (440 psi)	Max. 4 bar (60 psi)
Length of hose from pump to gun	30 m (98.4 ft)	15m (50 ft)	Up to 30 m (98.4 ft)	5 to 20 m (16.4 to 65.6 ft)
Diameter of hose	9.5 mm ID (3/8 in)	12.5mm (1/2 in)	19 mm ID (3/4 in)	19 mm ID (3/4 in)
Whip	0.5 m (1.6 ft) whip 6 mm (0.24 in) hose <i>Higher pressure required when whip used</i>	1 m x 9.5 mm (3.3 ft x 3/8 in.)	-	-
Diameter of nozzle	0.5 to 0.7 mm (0.019 to 0.029 in) (Reversible tip 419 to 429)	Reversible tip: 0.43 to 0.74 mm (0.017 to 0.029 in.)	2 mm (0.08 in)	2 mm (0.08 in)
Pump type	Ratio 70:1 piston pump	2.68 kW rated brushless DC motor	Ratio: 4:1 or greater Flow: 3 L/min (0.8 gal/min) 2-ball piston pump	20 litre (5.3 gal) bottom entry pressure pot
Air pressure requirement	2 to 5 bar (30 to 70 psi)	Site-air not required	Up to 7 bar (100 psi)	Pressure in gun: up to 6 bar (85 psi) Pressure in pot: max 4 bar (60 psi)

PRODUCT INFORMATION

Product	Decicoat T35
Weight	0.39 kg/m ² /mm DFT
Consumption for 1 mm (0.04 in) DFT <i>Includes allowance for up to 10% material shrinkage</i>	1.1 L/m ²
1mm DFT (dry film thickness) coverage using 19L pail	17 m ²

Substrates: Can be used on steel and aluminium.

Shelf life and Storage:

- 24 months from receiving goods (when stored under recommended conditions).
- Product to be stored and transported between 10 and 45 °C (50 to 113 °F).
- **Do not allow to freeze.**
- Partially used pails of the product can be reused if sealed firmly after first use.
- The opened product should be resealed and used within 2 months. Frequent opening of the seal must be avoided.

Clean up and Safety:

- Equipment easily cleaned with water
- Personal Protection Equipment (PPE) including eye protection, gloves and safety clothing are highly recommended.

Please contact Pyrotek® for further information or detailed advice on your specific application.

GRACO XTREME 70:1 PNEUMATIC PUMP

XTR-7 Airless Spray Gun



GNG/T3005 Texture Gun Bottom Entry

Bottom Entry Pressure Pot

ProSpray 3.39



For further information and contact details, please visit our website pyroteknc.com

Caveats: Specifications are subject to change without notice. The data in this document is typical of average values based on tests by independent laboratories or by the manufacturer and are indicative only. Materials must be tested under intended service conditions to determine their suitability for purpose. The conclusions drawn from acoustic test results are as interpreted by qualified independent testing authorities. Nothing here releases the purchaser/user from responsibility to determine the suitability of the product for their project needs. Always seek the opinion of your acoustic, mechanical and fire engineer on data presented by the manufacturer. Due to the wide variety of individual projects, Pyrotek is not responsible for differing outcomes from using their products. Pyrotek disclaims any liability for damages or consequential loss as a result of reliance solely on the information presented. No warranty is made that the use of this information or of the products, processes or equipment to which this Information Page refers will not infringe any third party's patents or rights. DISCLAIMER: This document is covered by Pyrotek standard Disclaimer, Warranty and © Copyright clauses. See pyroteknc.com/disclaimer.



Brochure





thermal insulation, anti-condensation
and corrosion protection

DECICOAT T35



Pyrotek[®]

SOUNDPROOFING SOLUTIONS FOR ALL INDUSTRIES
pyroteknc.com



SEAMLESS INSTALLATION - CONTROLS THERMAL BRIDGING

Thermal bridges are pathways for heat transfer, typically caused when insulation is not continuous. Being sprayable, Decicoat T35 bonds flush around uneven surfaces, tight areas and provides 100% coverage even around mechanical assemblies. This reduces the occurrence and impact of thermal bridging where even high performance foam insulation systems with radiant barrier faces fail.

Decicoat® T35 is a one-part, water based thermal insulation coating, specially formulated to provide excellent properties for anti-condensation and protection from corrosion under insulation (CUI).

LIGHTWEIGHT AND SPRAYABLE

It's a lightweight acrylic system, with excellent adhesion and non-sag formulation. It can be easily and quickly sprayed like paint with a range of spray systems.

THERMAL PROPERTIES

Decicoat T35 provides the benefits of both good thermal resistance (R value) and acts as a good radiant barrier (low emissivity). It controls both, rapid heat dissipation and heat absorption and exhibits increased performance with additional coatings thereby offering weight and space efficiency.

APPLICATIONS

- Marine vessels - interiors of structures and hulls in workboats, luxury yachts and super-liners etc
- Off-shore platforms - interior structures of habitable areas
- Industrial: the underside of metal deck roofing and metal wall cladding
- Automotive: heavy vehicles, buses, trailers, tractors.
- Rail cars: applied in conjunction with traditional fibrous or foam insulation to improve overall thermal insulation systems
- Domestic: pipes, walls, interiors
- Applications exposed to high humidity and temperature fluctuations

FIRE CERTIFICATION

Decicoat T35 achieves a wheelmark and complies with stringent international fire standards for building, industrial, rail and marine applications. It is low VOC and near odourless.

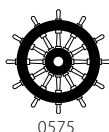

0575



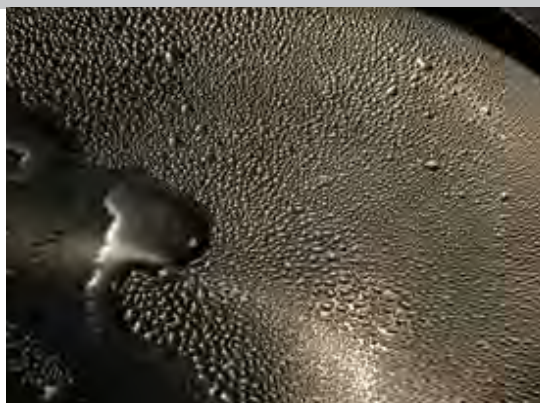

PREVENTS CONDENSATION

When thermal conduction takes place through a substrate, condensation occurs on the surface, when its temperature reaches the 'dew-point' threshold. i.e. the point of onset of condensation. Decicoat T35 has proven low thermal conductivity and permeability properties. When used on substrates exposed to high humidity or temperature variations, it inhibits thermal transfer and effectively regulates the temperature of the substrate surface to remain above the dew-point threshold, thereby preventing the onset of condensation.

PREVENTING CORROSION

Corrosion is a chemical and physical change that occurs in a material due to its interaction with its environment. Decicoat T35 provides a protective coating to metallic substrates, aiding in the prevention of condensation. Condensation can typically act as an electrolyte as part of galvanic corrosion. It will also cause dissolution of chloride and sulfide ion contaminants that exacerbate the corrosion process.

Decicoat T35 is formulated for ease of installation by spray application, directly onto ferrous and nonferrous surfaces.

INHIBITS CORROSION UNDER INSULATION (CUI)

Chemical contaminants typically found in materials such as glass wool or mineral fibre react with moisture trapped in the air gaps, under poorly installed insulation, to form an acidic reaction which corrodes the metallic substrate.

Corrosion under Insulation (CUI), is difficult to detect and treat in situ, and leads to degradation and reduced performance of the system over a period of time.

In eliminating the occurrence of thermal bridging, Decicoat T35 inhibits CUI and enhances the durability of such insulation systems. It maintains the overall thermal performance of the system besides offering a weight, space, cost and time efficient solution.

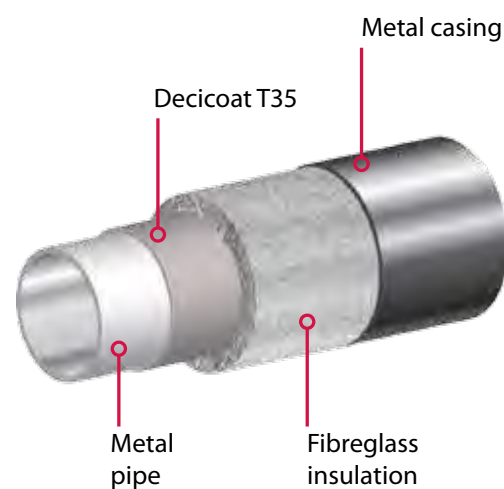
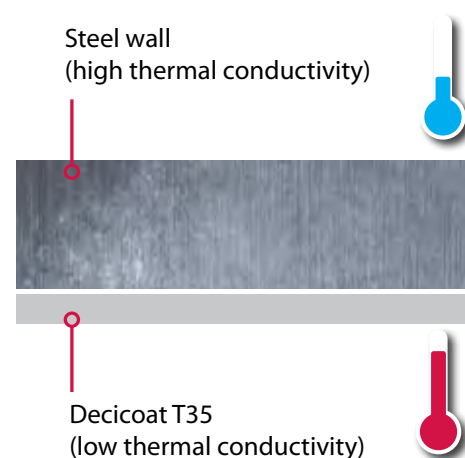



pyroteknc.com

PYROTEK WORLDWIDE LOCATIONS

AUSTRALIA

CANADA

CHINA

CZECH REPUBLIC

HONG KONG

INDIA

INDONESIA

JAPAN

KOREA

MALAYSIA

SINGAPORE

NEW ZEALAND

TAIWAN

THAILAND

TURKEY

UNITED ARAB EMIRATES

UNITED KINGDOM

UNITED STATES OF AMERICA

VIETNAM

CONTACT DETAILS

for further information and
contact details, please visit
our website at pyroteknc.com

Pyrotek endorse forest sustainability and the preservation of natural environment. We procure the highest quality materials from suppliers who hold FSC (Forest Stewardship Council) Certification and PEFC (Programme for the Endorsement of Forestry Certification) amongst other certification programmes.

Caveats: Specifications are subject to change without notice. The data in this document are typical of average values based on tests by independent laboratories or by the manufacturer and are indicative only. Materials must be tested under intended service conditions to determine their suitability for purpose. The conclusions drawn from acoustic test results are as interpreted by qualified independent testing authorities. Nothing here releases the purchaser/user from responsibility to determine the suitability of the product for their project needs. Always seek the opinion of your acoustic or mechanical engineer on data presented by the manufacturer. Due to the wide variety of individual projects, Pyrotek NC is not responsible for differing outcomes from using their products. Pyrotek disclaims any liability for damages or consequential loss as a result of reliance solely on the information presented. No warranty is made that the use of this information or of the products, processes or equipment to which this Information Page refers will not infringe any third party's patents or rights. **DISCLAIMER:** This document is covered by Pyrotek standard Disclaimer, Warranty and © Copyright clauses. See www.pyroteknc.com/disclaimer.



CASE STUDIES PROJECT LIST



SOUNDLAG™ SUCCESSFUL IN LARGEST EMIRATES HOTEL

Designed to resemble a traditional Arabian town, Madinat Jumeirah Hotel is a new 5 star Hotel built in Dubai with a total of 440 rooms. Located next to the iconic Burj Al Arab Hotel the Madinat Jumeirah Hotel is now the largest resort in the Emirate.

Complete with waterways, lush gardens and elegant accommodation, this private, beach front resort has over 40 restaurants and bars, 29 traditional summer houses, a waterpark, two grand ballrooms, and its own arena.

In such a large scale project, complexity and sheer volume becomes a challenge in terms of lagging. Knowing the luxury market who will frequent the hotel, noise issues from plumbing would not be tolerated, and thus the best quality, most effective solution would be required. For efficiency it also needed to be easy and fast to install.

With no specific acoustic parameters given from the MEP consultant (CKR Consulting Engineers), Soundlag™ 4525C was chosen specifically due to the maximum insertion loss amongst its competition. The flexibility of the barrier was what impressed the consultants as it makes the product easy to install.

Soundlag™ 4525C is to be installed throughout the Hotel. The unique construction of Soundlag pipe lagging gives the dual benefits of a noise barrier and a noise absorber. The highly dense and flexible mass layer provides excellent sound reduction properties, whilst the decoupling layer breaks the vibration path between the substrate and the mass barrier, thus allowing the vinyl external wrap to remain flexible and thereby optimise its performance. The external foil facing offers a fire resistant covering and an excellent surface to join adjacent sheets.

In total 10,120 m² will be installed throughout the hotel. At the time of writing (2016), the project is still under construction and as yet no testing has been completed.





MADINAT JUMEIRAH, DUBAI

Gold Coast University Hospital Project - Southport Queensland

The installation of cooling towers and emergency power generators for the Gold Coast University Hospital Project needed an outdoor noise enclosure for the surrounding Central Energy Plant Building. The specification required an effective sound absorption product that can be exposed to elements such as the coastal area and salt exposure. Pyrotek® delivered a sound solution, Reapor® - a non-combustible, soundproofing panel made from recycled glass with superior acoustic absorption.

Reapor® was installed using a c-channel structure and was applied both vertically and horizontally with the noise enclosure reaching up to 9 metres high. The product also allowed for easy machining for penetrations and is lightweight for more comfortable handling.

The Northern Wall (Level 2) inserted 1.2 x 625 mm Reapor® panels into the galvanised steel section resulting in a 6.5 m high wall. The Western Wall (Level 2) surrounding the emergency power generation machinery reached approximately 9 metres high. Each panel also has a silicone sealant applied to prevent vibration damaging the panels over long-term exposure to high noise levels.

The rigid, durable material is unaffected by weather, is lightweight, workable with conventional woodworking tools, easy to clean and repair, fibre free and safe to use. Reapor® exemplifies Pyrotek's commitment to exceed and stay ahead of growing community expectations for superior and innovative soundproofing products throughout their life cycle while delivering outstanding results.





Reapor® application at Gold Coast University Hospital Project

INDONESIAN COMMERCIAL BUILDING FACADE

A new high rise commercial building located in Sudirman Central Business District of Indonesia is using the highest standards to achieve great results. With German engineering, it is the first of its kind in Indonesia, and it has been awarded with the LEED Platinum Grade Pre-certification, granted by the US Green Building Council.

The aluminium facade, created by PT Shenyang Yuanda, posed a challenge for Pyrotek® to come up with an engineered solution. Solving this high impact noise problem was all in a day's work for the team. Due to the design of the building, during rain, noise impact from rain drops and wind can cause tinniness and ringing on aluminium façade panel, which would potentially reverberate throughout the building. Highly disruptive, it would mean great potential to receive major complaints from future tenants. Raw metal including aluminium can become acoustically excited due to impact noise. Put into perspective, this building hosts 40 floors, each with a façade made of aluminium, combined with a 2 mm thick tempered glass panel - over the 209.45 metres of high rise construction. Without a good acoustic solution, that is a lot of noise.

During a heavy rain fall, the untreated façade would emit high levels of noise, amplifying throughout the building adding up to a lot of disruption. With such a high level of noise building up, consideration of acoustic treatment was crucial to the design.

Decidamp® SP80 was suggested for the facade panels as this product is lightweight and highly effective for this type of application. Easily applied by an air pressure spray system including texture gun and bottom entry pressure spot, Decidamp® SP80 is a fast drying, water based viscoelastic vibration damping compound.

A total of 6,000 square metres of the aluminium façade was covered by Decidamp® SP80, PT Shenyang Yuanda found the application fast and lightweight, as it was an easy process and it was completed swiftly.



A total of 6,000 m² of the aluminium façade
was covered with Decidamp® SP80







Hamad International Airport (Doha International Airport)
Product: Quadzero™ NL
Application: Public areas
Quantity: 10 800 sqm (116 640 sqft)



A nighttime photograph of a city skyline, likely Tianjin, China. The most prominent feature is a tall, cylindrical skyscraper on the left, illuminated with vertical green lights. Other buildings are lit up in various colors, including yellow, white, and red. In the foreground, there are lower-rise buildings, a railway station with tracks, and a bridge with a white arch. The sky is dark blue with some clouds.

Tianjing Skyscraper Projects
Product: Silentstep RU
Application: Placed under the flooring in
multistorey buildings

PROJECT LIST

2018 Commonwealth Games Athletes Village	Soundlag	Australia
Australia 108	Soundlag™	Australia
Harold Park Apartments (HVAC)	Sorberpoly 2D GC	Australia
Sydney Airport Noise Amelioration Program	Quadzero™	Australia
Adelaide Airport Noise Insulation Programme	Quadzero™	Australia
Ritz Carlton Hotel, Elizabeth Quay	Soundlag™ Wavebar®	Australia
Gold Coast Hospital	Reapor®	Australia
Aire Apartments, South Perth	Soundlag™	Australia
Cooling Towers, Crown Towers	Viterolite® 300	Australia
DFO, Perth Airport	Wavebar®	Australia
Leading Bottleshop Store	Reapor®	Australia
Leading Service Station (Applecross)	Reapor®	Australia
Fulong Ballroom	Decidamp® SP80	Mainland, China
Huijin Marriott Hotel	Silentstep RU	Mainland, China
JW Marriott Hotel (Shanghai Luneng)	Silentstep RU	Mainland, China
Hilton Sanya	Silentstep RU Soundlag™	Mainland, China
Sanya Marriott Yalong Bay Resort & Spa	Soundlag™	Mainland, China

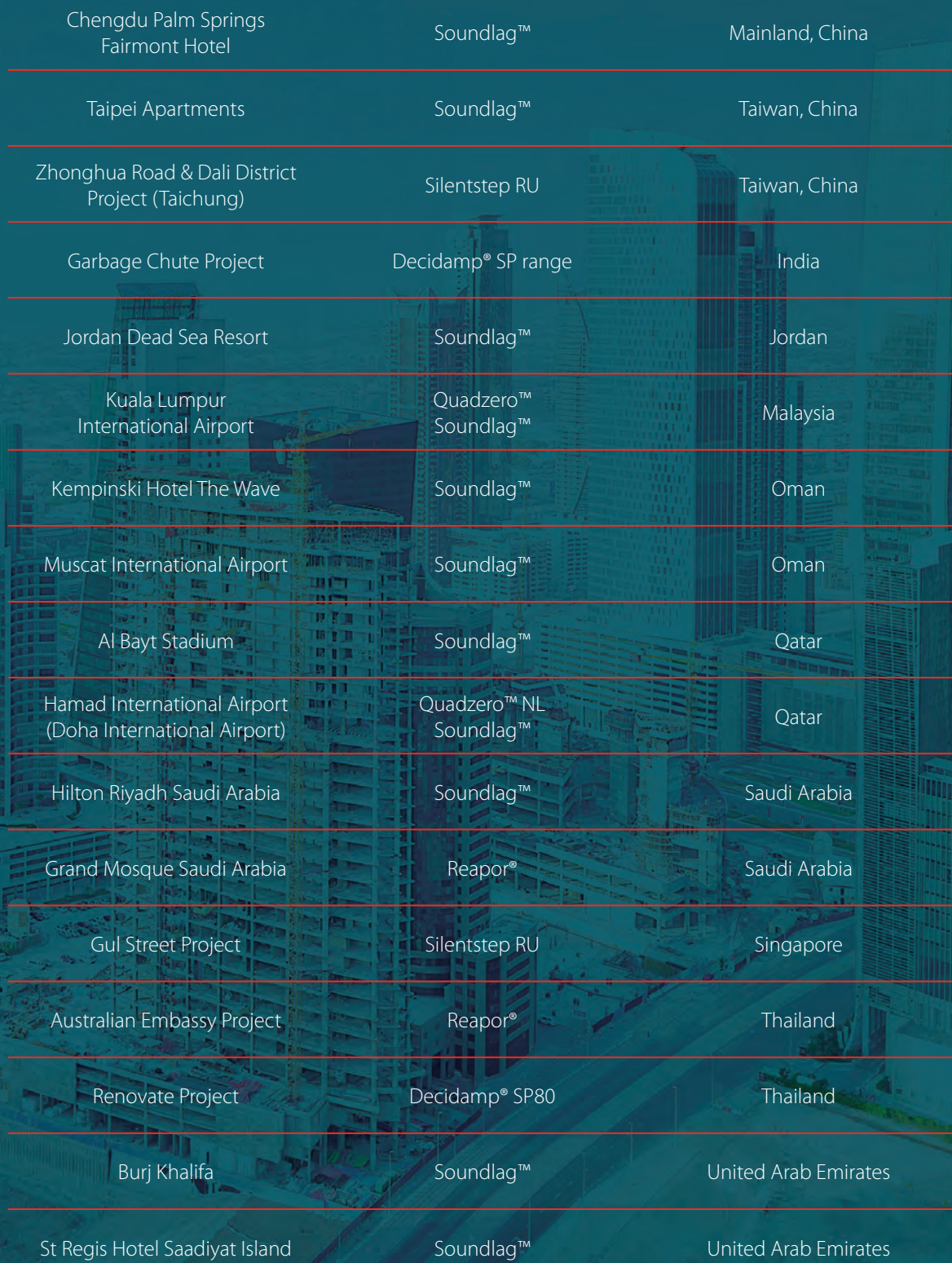

Chengdu Palm Springs Fairmont Hotel	Soundlag™	Mainland, China
Taipei Apartments	Soundlag™	Taiwan, China
Zhonghua Road & Dali District Project (Taichung)	Silentstep RU	Taiwan, China
Garbage Chute Project	Decidamp® SP range	India
Jordan Dead Sea Resort	Soundlag™	Jordan
Kuala Lumpur International Airport	Quadzero™ Soundlag™	Malaysia
Kempinski Hotel The Wave	Soundlag™	Oman
Muscat International Airport	Soundlag™	Oman
Al Bayt Stadium	Soundlag™	Qatar
Hamad International Airport (Doha International Airport)	Quadzero™ NL Soundlag™	Qatar
Hilton Riyadh Saudi Arabia	Soundlag™	Saudi Arabia
Grand Mosque Saudi Arabia	Reapor®	Saudi Arabia
Gul Street Project	Silentstep RU	Singapore
Australian Embassy Project	Reapor®	Thailand
Renovate Project	Decidamp® SP80	Thailand
Burj Khalifa	Soundlag™	United Arab Emirates
St Regis Hotel Saadiyat Island	Soundlag™	United Arab Emirates



pyroteknc.com

PYROTEK
WORLDWIDE LOCATIONS

AUSTRALIA

CANADA

CHINA

CZECH REPUBLIC

HONG KONG

INDIA

INDONESIA

JAPAN

KOREA

MALAYSIA

SINGAPORE

NEW ZEALAND

TAIWAN

THAILAND

TURKEY

UNITED ARAB EMIRATES

UNITED KINGDOM

UNITED STATES OF AMERICA

VIETNAM

CONTACT DETAILS

for further information please visit our website at pyroteknc.com

Pyrotek endorse forest sustainability and the preservation of natural environment. We procure the highest quality materials from suppliers who hold FSC (Forest Stewardship Council) Certification and PEFC (Programme for the Endorsement of Forestry Certification) amongst other certification programmes.

Caveats: Specifications are subject to change without notice. The data in this document are typical of average values based on tests by independent laboratories or by the manufacturer and are indicative only. Materials must be tested under intended service conditions to determine their suitability for purpose. The conclusions drawn from acoustic test results are as interpreted by qualified independent testing authorities. Nothing here releases the purchaser/user from responsibility to determine the suitability of the product for their project needs. Always seek the opinion of your acoustic or mechanical engineer on data presented by the manufacturer. Due to the wide variety of individual projects, Pyrotek is not responsible for differing outcomes from using their products. Pyrotek disclaims any liability for damages or consequential loss as a result of reliance solely on the information presented. No warranty is made that the use of this information or of the products, processes or equipment to which this Information Page refers will not infringe any third party's patents or rights. **DISCLAIMER:** This document is covered by Pyrotek standard Disclaimer, Warranty and © Copyright clauses. See pyroteknc.com/disclaimer.